



Co-botic™ 45

We shine together
Co-botic 45



A human-robot collaboration

The co-botic 45 is an intelligent robotic scrubber-dryer for hard floors. It's your perfect cleaning help for spaces between 200m²-1500m².

Savings per 500 m² vs. other manual machines



Electricity
75%



Water
60 liter



Time
90 min

Technical specifications



Run time
**up to 3h with
1x ipower 20C**



Practical performance
up to 700 m²/h

*in open areas, this varies
by environment

Why co-botic 45?



Faster

Cleans faster than manual and relieves the cleaner who can clean elsewhere in the meantime.



Cleaner

Optimizes cleaning routes via the co-botics™ app for all floor types, ensuring efficient and thorough cleaning.



Greener

Uses as little water as possible and around 800W less per hour than other manual machines.



Safer

Dries floors in 10 seconds and operates cordlessly, minimizing slip and fall hazards.



Better for everyone

Combine the performance of the co-botic with the human eye for modern cleaning, with minimal environmental impact.

Why the co-botic 45 is your choice:



1. The standard handle

Manually steer the co-bot to any location. Can also be used for mapping and manual cleaning.

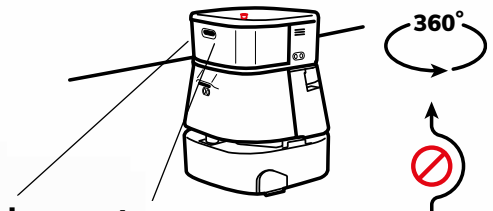

Never miss a spot

Stores every spot in memory. This way it never gets lost or miss a spot. Even when the floor is temporarily occupied.

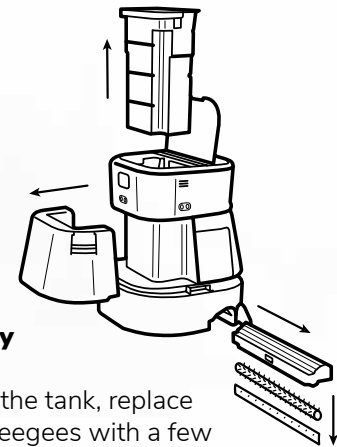

All parts easily accessible

Refill or empty the tank, replace brushes or squeegees with a few clicks.



Saves time



No detergents needed



Uses less water



Uses less power

M24.000013.01.EN - Subject to change.

Co-botic 45 special features:



It recognizes glass and mirror to get around them.



Never gets lost, or miss a spot even when the floor is temporarily occupied.



You can create a map of your cleaning spaces within minutes.

For more info about our product, visit: i-teamglobal.com