

# CO-BOTIC 65™

Continuously easy

## User manual



**i-team Professional b.v.**

Hoppenkuil 27b, 5626 DD Eindhoven, The Netherlands

Telephone: +31402662400

Email: [hello@i-teamglobal.com](mailto:hello@i-teamglobal.com)

Internet: [www.i-teamglobal.com](http://www.i-teamglobal.com)





### **FASTER:**

Clean large, medium, and small areas within no time. Because of its small turning radius, the i-drive can turn in narrow aisles. You can also fill, refill and empty the i-mop lite easily. Get fresh water from the i-drive, or empty the recovery tank into the i-drive by hose in a pinch.



### **CLEANER:**

The CO-BOTIC 65™ can carry an i-mop lite on its back, allowing the cleaner to hop on and hop off easily for a more detailed cleaning job. In short, the i-drive cleans your big spaces, while the i-mop lite allows you to efficiently clean smaller spaces.



### **GREENER:**

Thanks to the high mechanical power of the CO-BOTIC 65, we use less water and little to no chemicals for cleaning.



### **SAFER:**

The CO-BOTIC 65 is equipped with a ramp and adjustable footrest for better ergonomics. The front & rear safety lights and the base-mounted lights illuminate the floor, so you can even clean in dark spaces. Smart design ensures clear front view while driving. The squeegee and brushes retract during backup and driving automatically.



### **BETTER FOR EVERYONE:**

This machine covers the cleaning needs of supermarkets, stadiums, or any building with mixed smaller and larger spaces. Nice bonus: the cleaner has time to rest while driving! Enjoy the maneuverability and practical features of this smart duo.

---

Original user manual, written in the English Language

Future Cleaning Technologies B.V.

Hoppenkuil 27b, 5626 DD Eindhoven, The Netherlands

---

Teleremote device: +31402662400

Email: [hello@i-teamglobal.com](mailto:hello@i-teamglobal.com)

Internet: [www.i-teamglobal.com](http://www.i-teamglobal.com)

---

Model: CO-BOTIC 65™

Date: 13/12/2021

Product code: CO-BOTIC 65

Version: v.1.0



## Preface

Thank you for choosing the CO-BOTIC 65™, the automatic scrubber that cleans faster, cleaner, safer, greener, and is better for everyone. The battery operated CO-BOTIC 65 is equipped with two counter-rotating disc brushes that provide a deep scrub and a great cleaning result. The CO-BOTIC 65 significantly decreases the amount of water and chemicals needed, which leads to a greener result and reduces the risk of slippery floors.

Please read this manual carefully for important information and operating instructions before using the CO-BOTIC 65. Save this manual for future reference. This CO-BOTIC 65 will provide excellent performance. The best results will be obtained when the CO-BOTIC 65 is:

- regularly maintained per the CO-BOTIC 65 preventive maintenance instructions in this manual;
- regularly serviced per service instructions in the service manual;
- operated with reasonable care and caution;
- maintained with manufacturer supplied parts.

Whenever this manual refers to “the manufacturer”, it means: Future Cleaning Technologies B.V., an affiliate company of i-team in Eindhoven, the Netherlands. Whenever this manual mentions “the partner”, it refers to your local i-team resell and support service partner.

## Purpose of the user manual

The purpose of the user manual is to provide the user with information during the life of the CO-BOTIC 65 in such a way that the CO-BOTIC 65 is used correctly, efficiently and safely, even in the event of reasonably foreseeable misuse, as described in section 1.2 of this manual.

The user manual contains instructions regarding:

- personal operator safety;
- intended and non-intended use of the CO-BOTIC 65;
- instructions for daily use;
- maintenance instructions;
- storage conditions;
- disposal of the CO-BOTIC 65.

These instructions must be considered to avoid risks that could lead to physical and/or material damage.

## Target audience

This user manual is intended for operators of the CO-BOTIC 65 and their supervisors, as well as partners and importers.



## Operators of the CO-BOTIC 65™





The CO-BOTIC 65 may only be operated by a person who:

- has correctly read and understood the instructions in this manual;
- is trained by a certified service partner;
- works together with a certified service partner;
- is trained on a CO-BOTIC 65 before using it.

### Reading guide

All forward, backward, front, rear, right, and left indications in this manual refer to the operator sitting in the driving position on the operator's seat.

The following symbols and terms are used throughout this manual to alert the reader regarding safety issues and important information:

Symbol	Term	Explanation
	<b>WARNING</b>	Indicates a hazardous situation which, if the safety instructions are not followed, can lead to injuries of the operator or bystanders and light or moderate damage to the product or the environment.
	<b>CAUTION</b>	Indicates a hazardous situation which, if the safety instructions are not followed, can lead to light and/or moderate damage to the product or the environment.
	<b>ATTENTION</b>	Indicates a liability situation for which the manufacturer or its partners and affiliates cannot be held accountable for damages caused by non-compliance.
	<b>BATTERIES</b>	Indicates a battery-operated machine. Batteries must be charged according to the instructions in the separate class I battery charger user manual. Batteries must be disposed of according to your local laws and regulations.



# Content

Preface .....	3
Purpose of the user manual .....	3
Target audience .....	3
Operators of the CO-BOTIC 65™ .....	4
Reading guide.....	4
<b>1 Introduction.....</b>	<b>8</b>
1.1 Intended use of the product.....	8
1.2 Non-intended use of the product.....	8
1.3 Lifespan.....	9
1.4 Modifications.....	9
1.5 Specifications.....	10
1.6 Warranty.....	11
1.7 Identification .....	11
<b>2 Description .....</b>	<b>12</b>
2.1 Control panel on the steering wheel .....	13
2.1.1 Multifunctional display.....	14
2.1.2 Codes alarm display .....	15
2.2 App on remote device .....	17
2.2.1 Notifications.....	18
2.3 Ignition key .....	19
2.4 Solution level indicator .....	19
2.5 Different types of squeegee blades.....	19
2.6 Disc brushes and pads .....	19
2.7 Cleaning agent .....	20
2.8 Safety features on the CO-BOTIC 65™ .....	20
2.8.1 Emergency stop.....	20
2.8.2 Emergency cut-out.....	20
2.8.3 Emergency button.....	21
<b>3 Safety.....</b>	<b>22</b>
3.1 General safety instructions.....	22
3.1.1 Sweep before scrub.....	22
3.1.2 Disc brush condition.....	22
3.1.3 Batteries .....	22
3.1.4 Safety laser scanner .....	23
3.2 Risks during operation.....	23
3.2.1 Dress adequately.....	23
3.2.2 Mark the job site .....	23
3.2.3 Careful when parking .....	23



3.3	Risks during automatic operation.....	23
3.4	Risks after operation.....	23
3.4.1	Remove battery packs.....	23
4	Transport and storage.....	24
4.1	General.....	24
4.2	Transport outside.....	24
4.3	Transport in a vehicle.....	24
4.3.1	Removal of bumper.....	25
4.4	Pushing or towing the CO-BOTIC 65™.....	25
5	Assembly and installation.....	26
5.1	Unboxing.....	26
5.1.1	Contents of the delivery.....	26
5.2	Assembly.....	27
5.2.1	Attaching the disc brushes and brush covers.....	27
5.2.2	Attaching the squeegee.....	27
5.2.3	Inserting the batteries.....	27
5.2.4	Load the i-mop® lite.....	27
5.2.5	Link the remote device.....	27
6	Operation.....	28
6.1	Before you start.....	28
6.1.1	Adjusting the seat.....	28
6.1.2	Inserting the batteries.....	28
6.1.3	Filling the detergent tank.....	30
6.1.4	Filling the solution tank.....	31
6.1.5	Checking the solution level.....	32
6.2	Operation procedure manual mode.....	33
6.2.1	Driving manual on the jobsite.....	33
6.2.2	Using reverse drive.....	34
6.2.3	Using the horn.....	34
6.2.4	At the job site manual mode.....	35
6.2.5	Working in ECO mode.....	36
6.3	Operation procedure automatic mode.....	36
6.3.1	Checking the remote device.....	36
6.3.2	Driving automatic on the jobsite.....	38
6.3.3	At the job site automatic mode.....	40
7	Maintenance.....	42
7.1	Cleaning the CO-BOTIC 65.....	42
7.1.1	Cleaning the machine.....	42
7.1.2	Cleaning the safety laser scanner.....	42
7.2	Checking the machine operating hours.....	43
7.3	Maintenance tasks on the squeegee.....	44
7.3.1	Removing the squeegee body from the squeegee lifting plate.....	44
7.3.2	Placing the squeegee body back on the squeegee lifting plate.....	45
7.3.3	Cleaning, checking and replacing the squeegee blades.....	45



7.4	The disc brushes .....	48
7.4.1	Removing the disc brushes.....	48
7.4.2	Placing back the disc brushes.....	49
7.4.3	Cleaning the disc brushes.....	49
7.4.4	Replacing the disc brushes .....	50
7.4.5	Replacing the pads .....	50
7.5	Cleaning the recovery tank.....	51
7.5.1	Cleaning the separator .....	52
7.5.2	Cleaning the recovery water inlet.....	53
7.6	Cleaning the detergent filter and detergent tank .....	53
7.7	Charging the batteries .....	56
7.8	Unloading, loading and refilling the i-mop® lite .....	58
7.8.1	Unloading and loading .....	58
7.8.2	Refilling the cleaning solution tank of the i-mop lite .....	58
7.9	Cleaning the i-mop® lite plateau .....	59
7.10	Cleaning the suction line .....	60
7.11	Cleaning the water filter .....	61
7.12	Damaged or worn parts.....	62
7.13	Maintenance frequency .....	63
7.13.1	Maintenance frequency table.....	63
7.13.2	Servicing the CO-BOTIC 65™ .....	64
7.14	Storage.....	64
8	Troubleshooting .....	65
9	Decommissioning and disposal .....	66
10	Attachments.....	67
10.1	CE Certificate .....	67
10.2	Specifications.....	68



# 1 Introduction

The CO-BOTIC 65™ is an easy and safe machine to use in manual and automatic mode. This manual will get you started and explain the operation of both manual and automatic operation and maintenance procedure. You will be pleasantly surprised by the fast and effective use of the battery operated CO-BOTIC 65. The battery packs contain the standard Li-ion battery used in various i-team products. When fully charged before use, the CO-BOTIC 65 will operate up to 2 hours, depending on the brush pressure, surface and driving speed. Please refer to the user manual of the i-charge 9® for correct procedure.

This manual is intended for those who work with the CO-BOTIC 65 and perform daily maintenance. The manual must be read in full before the first actions. This manual describes the correct method of use, safety measures, maintenance and transport.

The programming of the CO-BOTIC 65 and the service instructions are described in the service manual.

i-team Professional continuously improves all its products based on user experience and feedback. Any deviations between the texts and/or images from the manual and your product can therefore arise from a difference in version or from possible changes due to continuous development and innovation.

## 1.1 Intended use of the product

The CO-BOTIC 65 is a specialized machine for scrubbing hard floor surfaces, in civil and industrial environments, under verified safe conditions, and must be driven or operated by a qualified operator. It is intended for use indoors and in a dry environment only. You must only use foam reduced detergents. Foam from normal scrubbing detergent will damage the vacuum motor.



### CAUTION

Dish washing soap is not suitable as a scrubbing detergent. It creates too much foam and can damage the vacuum motor and voids the warranty.

## 1.2 Non-intended use of the product



### WARNING

Non-intended use can have consequences for the safety of operators and bystanders and will void the warranty on the product.

- do not use the CO-BOTIC 65 to clean carpets or rugs;
- never operate the CO-BOTIC 65 near stairs, escalators or any area with a significant drop in elevation;
- do not use the CO-BOTIC 65 without a falling objective structure (FOPS) in areas where it is likely that the operator is hit by falling objects;
- do not fill the CO-BOTIC 65 with any flammable detergent. ONLY use water-based cleaning solutions;
- do not use water that exceeds 113° F/45° C. Using water above this temperature will void the tank warranty;
- do not use cleaning solutions with pH below 3 or above 11 in order to prevent damage to sensitive components;





- do not use the CO-BOTIC 65™ near devices that could generate strong electromagnetic waves as it could affect the operation of the machine;
- do not use the CO-BOTIC 65 on rough surfaces. The CO-BOTIC 65 is designed for smooth, hard flat surfaces only (less than 2% slope). Rough surfaces will not give the desired result and increase the wear on the disc brushes;
- do not use the CO-BOTIC 65 on surfaces exceeding the maximum allowed slope gradient;
- do not operate this CO-BOTIC 65 over electrical floor outlets to avoid electrical shock;
- do not use the CO-BOTIC 65 to scrub oil, diesel, petrol or other chemical components. While the CO-BOTIC 65 wheels are resistant to oil, diesel or petrol chemicals will contaminate the wastewater and the recovery tank, as well as the disc brushes and squeegee. Oil resistant squeegee blades and disc brushes are available;
- do not use the CO-BOTIC 65 as stepladder or platform;
- do not carry passengers on top of the CO-BOTIC 65, no riders;
- do not use the CO-BOTIC 65 as a transport device;
- do not sit or hang on the CO-BOTIC 65 while the machine is working in automatic mode;
- do not store the CO-BOTIC 65 outside in order to avoid damage to electronic components;
- never operate the CO-BOTIC 65 near flammable dusts, liquids or vapors;
- never operate the CO-BOTIC 65 when flammable or poisonous liquids like gasoline, oil, acids, or other volatile substances are on the floor;
- keep away from children! The CO-BOTIC 65 is a professional cleaning machine to be used by trained adult operators;
- only use manufacturer-supplied parts for maintenance;
- remove the ignition key to prevent unauthorized personnel from using the CO-BOTIC 65;
- do not leave the CO-BOTIC 65 unattended without ensuring that it cannot move by itself;
- do not drive the CO-BOTIC 65 on public roads;
- do not use the CO-BOTIC 65 in insufficiently lit or highly dusty environments;
- do not remove or copy the location marker and start point markers.
- do not change the route or alter the program;
- do not remove the app from the remote device.

### 1.3 Lifespan

To ensure proper and safe operation throughout the life of the CO-BOTIC 65, the machine must be checked and serviced by an authorized i-team partner, see also section 7.13.2.

### 1.4 Modifications

It is not permitted to make modifications to the design of the CO-BOTIC 65 without consultation and permission from the manufacturer. Doing so affects the warranty, see section 1.6.



## 1.5 Specifications

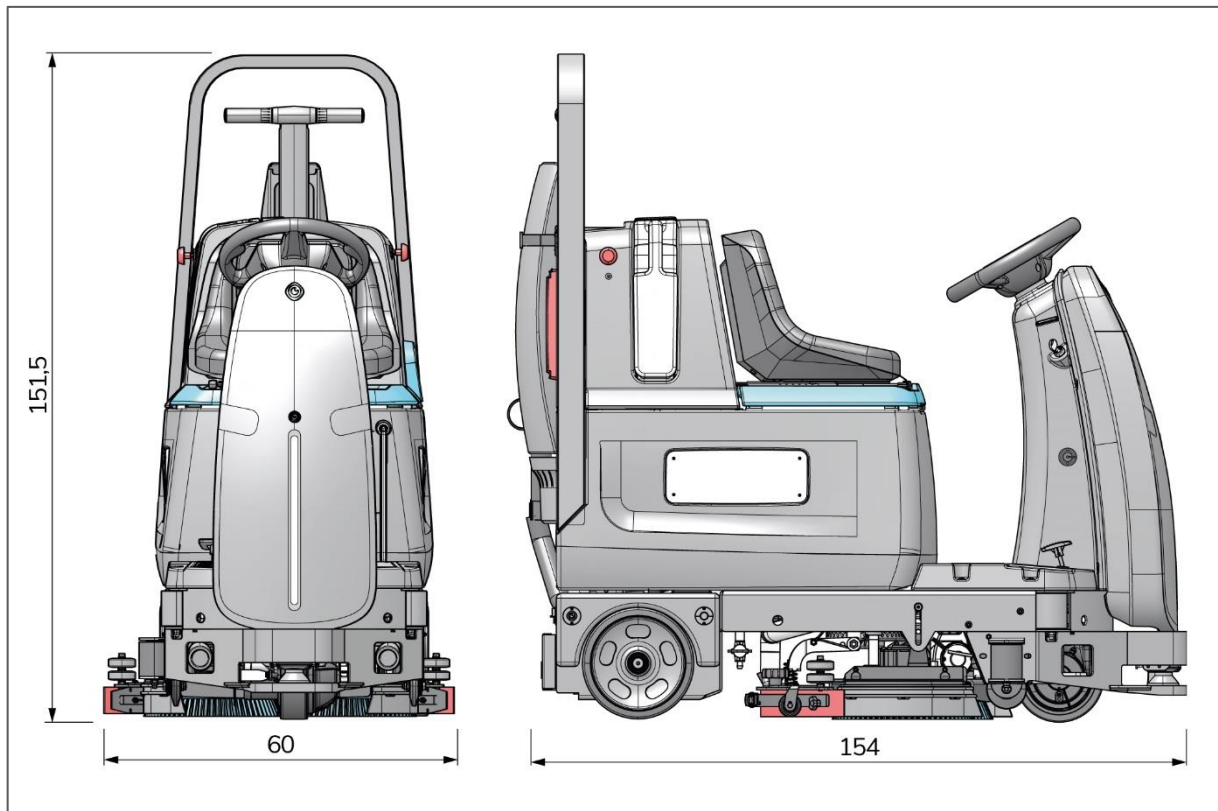

Figure 1

Machine size (L x W x H):	154 x 60 x 151.5 cm
Working width disc brush deck:	61 cm
Working width squeegee:	79 cm
Typical Operational Weight (GVV) (CO-BOTIC 65™ with 6 Li-Io batteries + i- mop lite + chemical tank):	208 kg
Gross Vehicle Weight (GVW automatic) (CO-BOTIC 65):	274 kg
Gross Vehicle Weight (GVW manual) (CO-BOTIC 65 incl. 75 kg for operator):	349 kg
Li-on batteries:	DC (25.2V, 14 Ah, 2117 Wh in total)
Battery capacity:	6 batteries *14 Ah = 84 Ah
Operation time of batteries:	120 min
Operating temperature:	5° C up to +40° C
Storage temperature:	-20° C up to +70° C
Humidity:	30% up to 90%
Disc brush pressure:	24.8 gr/cm <sup>2</sup>
Disc brush speed:	175 RPM
Solution tank capacity:	58 L
Detergent tank capacity:	5.5 L
Recovery tank capacity:	54 L
Vibration:	Acceleration: 0.299 m/s <sup>2</sup>



Noise levels:	Operators ear when seated: LpAT=64,3 dB(A) Average around the machine: Lpf=68,5 dB(A) Sound power (sticker): LwA=84,4 dB(A)
Theoretical performance (automatic):	2196 m <sup>2</sup> per hour
Theoretical performance (manual):	2745 m <sup>2</sup> per hour
Practical performance (automatic):	1118 m <sup>2</sup> per hour
Practical performance (manual):	1400 m <sup>2</sup> per hour
Speed:	Forward (automatic): max. 3.6 km/h Forward (manual): max. 4.5 km/h Reverse (manual): max. 3 km/h
Turning circle:	Left: 166 cm Right: 215 cm
Maximum slope normal operation:	2%
Maximal truck ramp (without bumper and safety laser scanner):	18%
Working lights:	YES
Autobrake:	YES
i-mop lite storage:	YES
Disc brush wear indicator:	YES
Operation-hour counter:	YES

## 1.6 Warranty

The CO-BOTIC 65™ should be used as intended and described in this manual. Using the CO-BOTIC 65 outdoors will void the warranty on the product.

The CO-BOTIC 65 should only be operated with the materials supplied. Using alternative supplies may cause damage to the CO-BOTIC 65 and may cause a risk to the operator. The use of alternative supplies voids the manufacturer's warranty. The warranty period is 1 year.

## 1.7 Identification

Each CO-BOTIC 65 has a unique serial number that can be found on the type plate (Figure 2) on the platform for the i-mop lite, at the back side of the CO-BOTIC 65. Your i-team partner needs this number when you order parts.

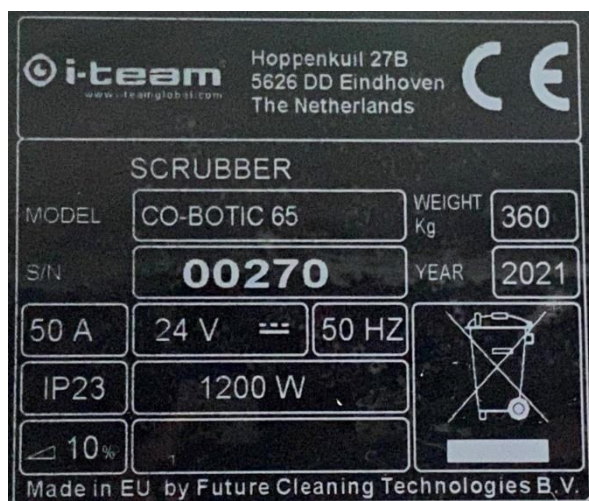

Distributor:  
i-team Professional  
Hoppenkuil 27 b  
NL-5626 DD Eindhoven

Product type: SCRUBBER  
Model: CO-BOTIC 65  
Serial number: 00270

Figure 2



## 2 Description

The CO-BOTIC 65™ consists of the following parts:

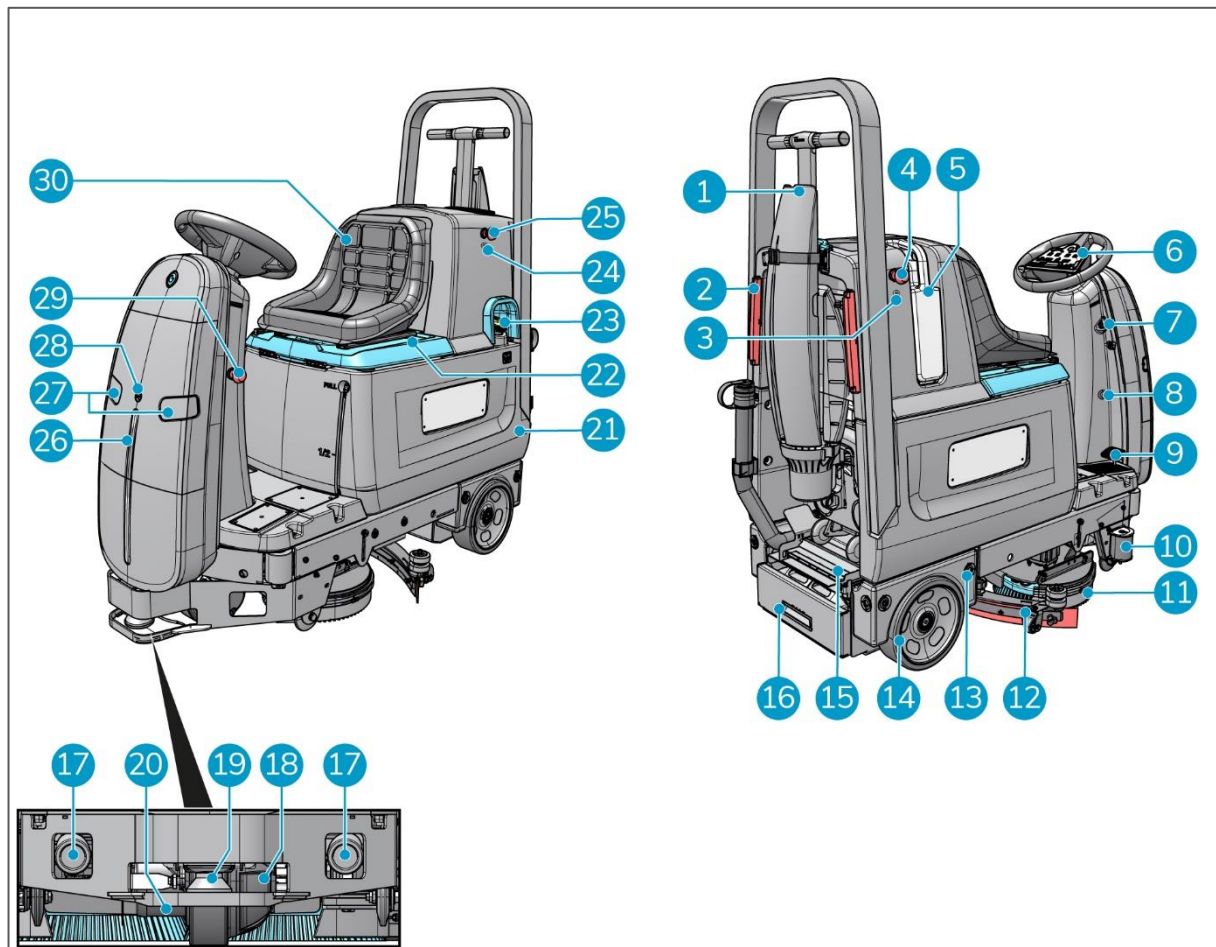

Figure 3

1. An i-mop lite.
2. Three tail lights.
3. An emergency stop indicator.
4. A tail emergency stop button.
5. A detergent tank.
6. A control panel and steering wheel.
7. An ignition key.
8. A service entry point.
9. An accelerator pedal.
10. Two tilt protection wheels.
11. Two rotating disc brushes.
12. A squeegee and a vacuum hose.
13. Seven automatic mode sensors.
14. Two back-wheels (25 x 7.5 cm).
15. An i-mop lite ramp.
16. A battery drawer.
17. Two work lights.
18. A front-wheel (20 x 6 cm) motor.
19. A safety laser scanner.
20. An electromagnetic autobrake.
21. A recovery and solution tank.
22. A recovery tank lid.
23. An opening to fill the solution tank.
24. An emergency stop light.
25. A tail emergency stop button.
26. A front light.
27. Two direction indicators.
28. A camera.
29. A front emergency cut-out button.
30. An adjustable operator seat.



## 2.1 Control panel on the steering wheel

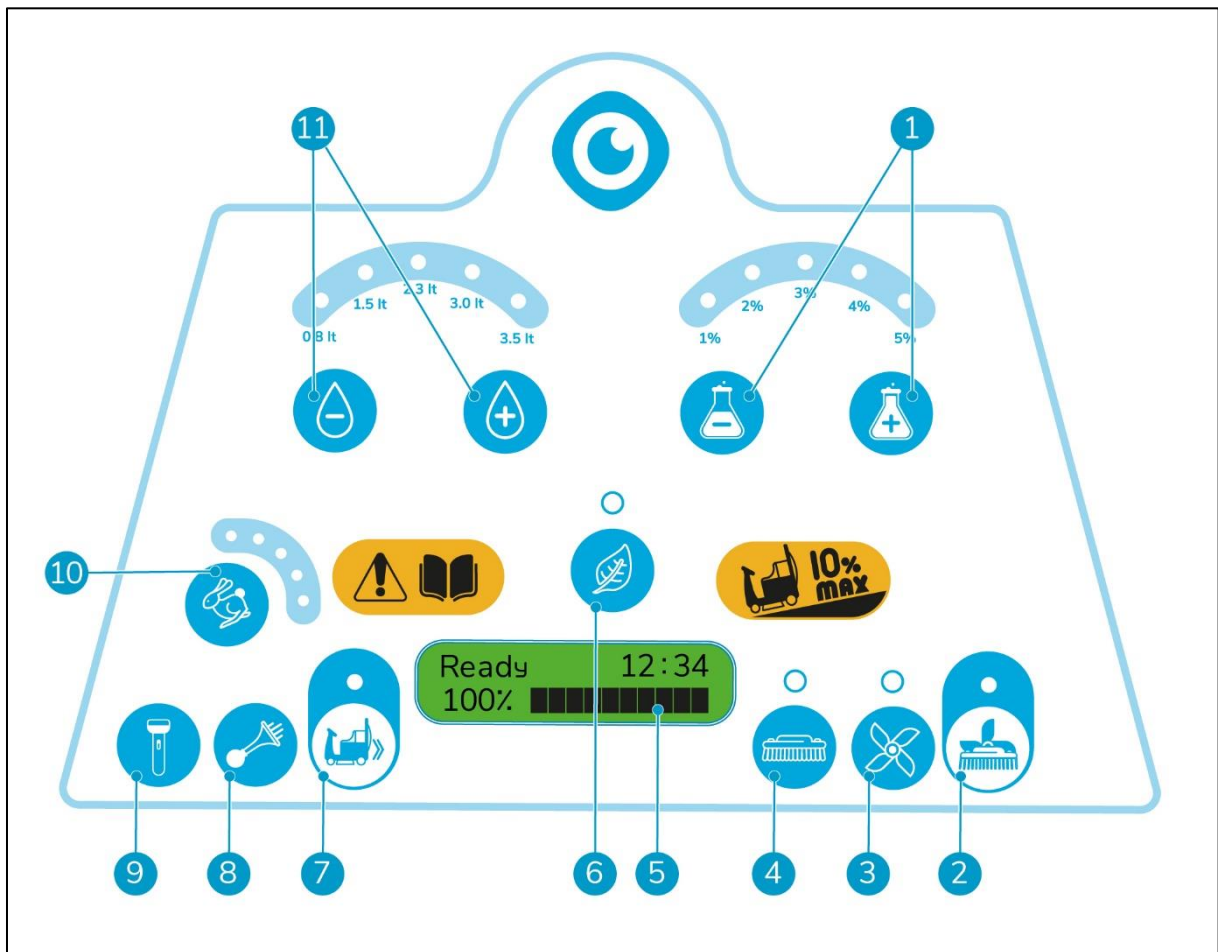

Figure 4

1. Detergent consumption, proportional to water consumption. Push the (-) touch button to diminish the consumption. Push the (+) touch button to increase the detergent consumption. There are five different levels indicated by the LEDs in the blue arch:
  - 1 LED on: 1%
  - 2 LEDs on: 2%
  - 3 LEDs on: 3%
  - 4 LEDs on: 4%
  - 5 LEDs on: 5%
2. Combined squeegee and disc brush ON/OFF touch button.
3. Squeegee and vacuum ON/OFF touch button.
4. Disc brush ON/OFF touch button.
5. Multifunctional display. See section 2.1.1
6. ECO mode ON/OFF touch button. If you switch the ECO mode to "ON", the voltage level on the disc brushes and vacuum motor is decreased by 30%. It does not slow down the speed of the CO-BOTIC 65™.
7. Reverse touch button. If reverse is activated, the CO-BOTIC 65 produces a sound and it drives at a reduced speed.
8. Horn touch button.
9. Working lights ON/OFF touch button.





10. Speed adjustment touch button. Five different speed levels, indicated by the LEDs in the blue arch. Push the push button to increase/decrease the speed. There are five different speed levels indicated by the LEDs in the blue arch:
  - 1 LED on: Max. 2.5 km/h
  - 2 LEDs on: 2.5 km/h
  - 3 LEDs on:
  - 4 LEDs on:
  - 5 LEDs on: Max. 4.5 km/h
- 11 Water consumption. Push the (-) button to diminish the water consumption. Push the (+) button to increase the consumption. There are five different levels indicated by the LEDs in the blue arch:
  - Level 1: 0.8 L/min (≈78 minutes using a full tank)
  - Level 2: 1.5 L/min
  - Level 3: 2.3 L/min
  - Level 4: 3.0 L/min
  - Level 5: 3.5 L/min (≈18 minutes using a full tank)

### 2.1.1 Multifunctional display

The multifunctional display gives the status of the CO-BOTIC 65™, alarm codes in manual mode and in automatic mode.

1. Manual mode:
  - Indicates operation time in hours and minutes (Figure 5, pos 1).
  - Indicates battery discharging level (Figure 5, pos 2).
  - Indicate mode: Ready for manual mode or Automatic for automatic mode (Figure 5, pos 3).
  - Indicates alarms with code number and short description, see also section 2.1.2.
  - Indicates "Schedule service".

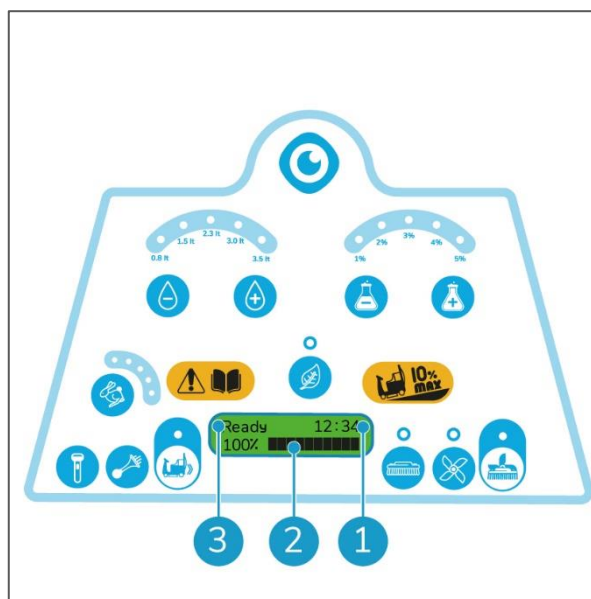

Figure 5



## 2.1.2 Codes alarm display



### ATTENTION

In case an alarm code occurs on the display, please contact service personnel or your i-team partner.

Alarm summary table control panel		
Alarm	Description	Solution
AL_1: Function Brushes Ammeter	Brushes ammeter protection.	Check brushes motor working current. Excessive and continuous working current detected on the brushes motor.
AL_2: Function Vacuum Ammeter	Vacuum ammeter protection.	Check vacuum motor working current. Excessive and continuous working current detected on the brushes motor.
AL_3: Function Power stage Fail	Power circuit damaged.	Brushes or vacuum power circuit damaged: replace the power board. The alarm may also be displayed if the machine is started when being towed or moving.
AL_4: Function Overcurrent	Brushes or vacuum overcurrent.	Short circuit on brushes or vacuum motor detected: check wirings and motors.
AL_5: Function Overtemperature	Brushes or vacuum circuit overtemperature.	Brushes and vacuum circuit power stage overtemperature: check if disc brushes run freely. Measure voltage output.
AL_7: Function Act2 endsw fail	Squeegee actuator limit switch reading failure.	Limit switch setting failure. Check connections and squeegee end switch position.
AL_8: Function Act1 timeout	Brush actuator movement over the time limit (12s):	Check connections and any mechanical obstructions.
AL_9: Function Act2 timeout	Squeegee actuator: end switch position not reached.	Squeegee actuator position not reached within the maximum time set. Check actuator connections and/or any mechanical obstructions.
AL_10: Function Solution Level	Solution tank level switch is activated.	The water level switch protects the water pump from running dry. Check whether the solution tank is empty, the switch is disconnected or there is a failure with the switch itself.
AL_11: Function Water Level	Recovery water tank full.	Empty recovery tank. Check if the recovery tank floating switch works correctly.
AL_13: Traction Pedal Failure	Pedal tear.	Check pedal potentiometer wirings.
AL_14: Traction Release Pedal	Pedal active at power on.	Moving switch active at power on: release the pedal.
AL_15: Traction Overtemperature	Traction circuit overtemperature.	Traction power stage overtemperature: check absorption.
AL_16: Traction Power stage Fail	Traction circuit damaged.	Traction circuit damaged: replace the power board. The alarm may also be displayed if the machine is started when being towed or moving.
AL_17: Traction Overcurrent	Traction overcurrent.	Short circuit on traction motor detected: check wirings and motors.
AL_18: Traction Tract. Ammeter	Traction ammeter protection.	Check traction motor's working current. Traction motor excessive overcurrent detected.
AL_19: Traction Motor Voltage	Internal reading mistake.	If failure persists, replace board.
AL_20: General EEPROM Failure	Internal eeprom reading error.	Replace board.
AL_21: General Key-off failure	Key-reading failure.	Rebound detected on the key signal: check battery-keyboard-function card connections.
AL_22: General Main relay failure	General relay damaged.	The general relay on the board looks damaged: replace the board. The alarm is triggered even in the event of a damaged power fuse.
AL_23: General Overvoltage	Overvoltage.	Function card overvoltage detected. Check battery connections.
AL_24: Traction Batt connection	Battery voltage < 10V.	Recharge batteries. If the batteries have been charged and the alarm occurs, check for loose connections between battery and electronic board.
AL_25: General Keyboard fail	Display-function card communication error.	Check connections between display and function card.
E_1: No Connection	No Wi-Fi connection.	Check if the machine is in range of the Wi-Fi router and if the Wi-Fi network is operational.
E_2: Battery Low	Battery below 20%, automatic cleaning not allowed.	Recharge batteries.
E_3: Low water	Solution tank empty.	Refill solution tank. If the malfunction continues see AL_10.
E_4: Recovery tank full	Recovery tank full.	Empty recovery tank. Check if the recovery tank floating switch works correctly.



<b>Alarm summary table control panel</b>		
<b>Alarm</b>	<b>Description</b>	<b>Solution</b>
ES_1: Emergency stop: Button pressed	Emergency stop button pressed.	Release emergency button, (re)start automatic route from the app.
ES_2: Emergency stop: Safety laser scanner activated	Emergency stop because safety laser scanner has been activated.	Clear path in front of machine. Reset machine by pushing and releasing an emergency button, (re)start automatic route from the app.
ES_3: Emergency stop: Seat switch activated	Emergency stop because seat switch is activated.	Clear seat from object(s). Reset machine by pushing and releasing an emergency button, (re)start automatic route from the app.
ES_4: Emergency stop: Safety laser scanner contaminated	Emergency stop because safety laser scanner window is contaminated.	Clean safety laser scanner window. Reset machine by pushing and releasing an emergency button, (re)start automatic route from the app.
SF_1: Steer enc error	Steering encoder timeout.	Restart machine, if persistent call certified Service partner.
SF_2: Steer enc error	Steering encoder stale measurement.	Restart machine, if persistent call certified Service partner.
SF_3: Wheel enc error	Rear wheel encoder timeout.	Restart machine, if persistent call certified Service partner.
SF_4: Wheel enc error	Rear wheel encoder stale measurement.	Restart machine, if persistent call certified Service partner.
SF_5: Steer syst fail	Fault in steering system.	Restart machine, if persistent call certified Service partner.
SF_6: Comm error	No communication to RIM.	Restart machine, if persistent call certified Service partner.
SF_7: Comm error	No communication to machine controller.	Restart machine, if persistent call certified Service partner.
SF_8: Comm error	No communication between internal computer.	Restart machine, if persistent call certified Service partner.
SF_9: Steel calib fail	Steering calibration failure.	Turn ignition key to manual, then manually calibrate steering wheel by turning it completely to left and right. Retry automatic mode, if persistent call certified Service partner.
SF_10: Safety laser scanner dat fail	No safety laser scanner Data being received.	Restart machine, if persistent call certified Service partner.
SF_11: Safety laser scanner contam	Safety laser scanner window contaminated.	Clean Li DAR window, turn ignition key to manual mode. Retry automatic mode, if persistent call certified Service partner.





## 2.2 App on remote device

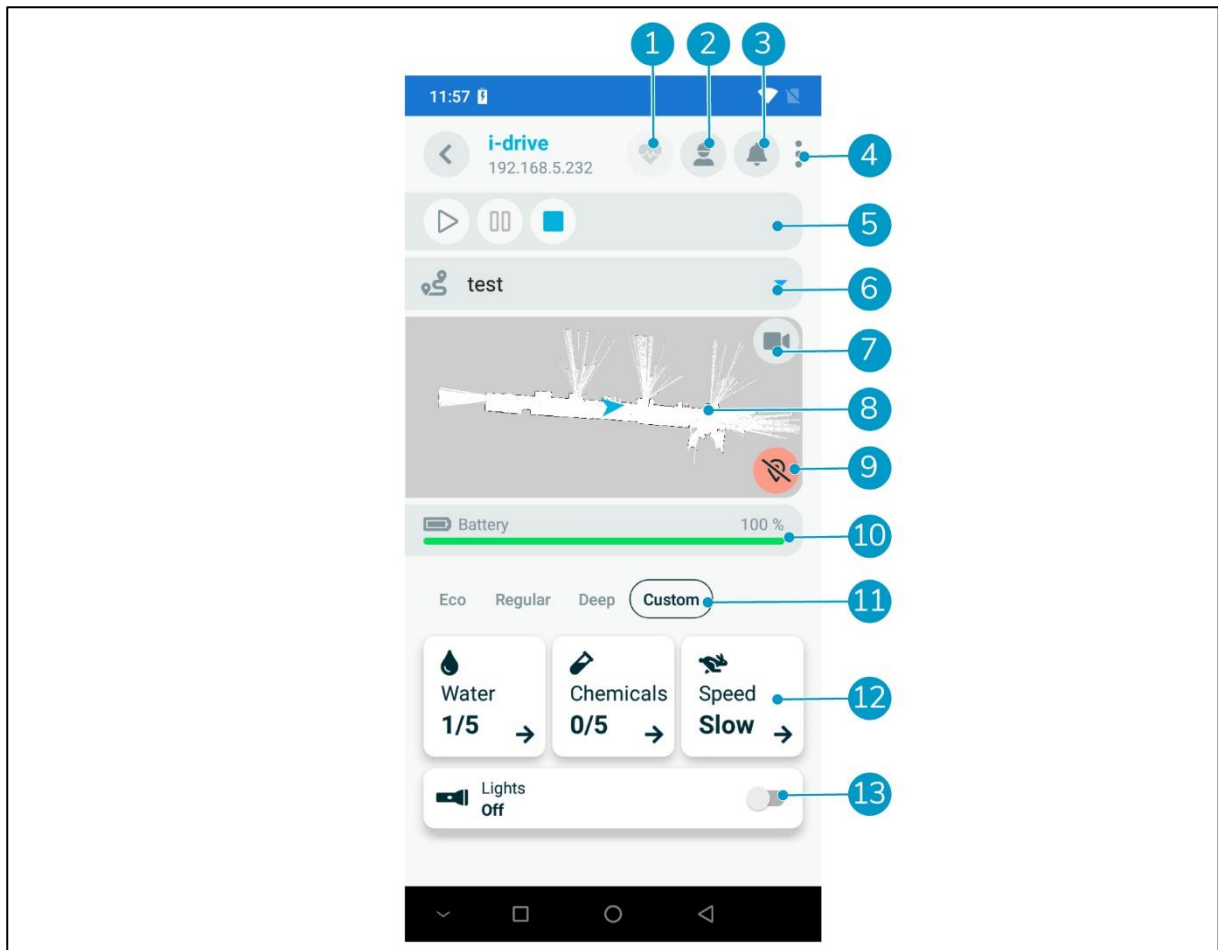

Figure 6

1. Connection indicator. When a good connection is established with the machine, it becomes blue.
2. Mode button. A person means manual mode and a robot means automatic mode.
3. Error button. Shows the error message window.
4. History button. Shows the cleaning history window. The cleaning history is displayed with day, time and run time.
5. Manually start, pause or stop the route of the machine.
6. Click on the arrow to expand. In this window the route within the map can be selected.
7. Camera button. Shows the view of the front camera of the machine.
8. Shows a map of the selected route and the location where the machine thinks it is.
9. Location indication. When the machine is localized it will turn green and disappear.
10. Battery discharging level.
11. Select a cleaning mode:  
"ECO:", "Regular" or "Deep" mode with default settings and "Custom" with adjustable settings.

Mode	Water	Chemicals	Speed
ECO:	Level 1	Level 1	Slow
Regular:	Level 3	Level 3	Fast
Deep:	Level 5	Level 5	Slow
Custom:	Choose level 1-5	Choose level 1-5	Choose Fast or Slow
12. Shows the settings of the water, chemicals and speed. In custom mode these are adjustable by clicking on them.
13. Turn the working lights on/off.



## 2.2.1 Notifications

Warning	Description	Solution/Action
Failed to start route, seat switch is activated	Driver or other goods on driver's seat	Leave the driver's seat or move the goods from the seat
Failed to start route, machine not localized	Computing system has lost the localization information	Repeat the localization procedure for the CO-BOTIC 65™ <ul style="list-style-type: none"> <li>• See 6.3.2 point 6</li> <li>• Press OK in the Warning window</li> </ul>
Failed to start route, object is in front of device	The safety laser scanner has an object detected	Remove the object in the viewing area of the CO-BOTIC 65 <ul style="list-style-type: none"> <li>• Press OK in the Warning window</li> <li>• CO-BOTIC 65 will start the route</li> </ul>
Failed to start route, e-stop button is pressed	One of the two emergency stop buttons on the CO-BOTIC 65 is activated	Check why the emergency stop button was activated <ul style="list-style-type: none"> <li>• After clearing the situation release the emergency stop button</li> <li>• Press OK in the Warning window</li> <li>• Press start (Figure 32, pos 11) on the app</li> </ul>
Error(s) detect on the device –emergency stop by device	An object is in the viewing area of the safety laser scanner. The object is very close to the CO-BOTIC 65	Control the viewing area of the CO-BOTIC 65 and remove the object <ul style="list-style-type: none"> <li>• Press OK in the Warning window</li> <li>• Press the emergency stop button</li> <li>• Release the emergency stop button</li> <li>• Press start (Figure 32, pos 11) on the app</li> </ul>
Error(s) detect on the device-route is obstructed by an object	An object is in the viewing area of the safety laser scanner	Remove the object in front of the CO-BOTIC 65. <ul style="list-style-type: none"> <li>• Control the viewing area of the CO-BOTIC 65 and remove the object in the device's path</li> <li>• Press OK in the Warning window</li> <li>• The CO-BOTIC 65 will continue automatically once the path is free</li> </ul>
Error(s) detect on the device.		Check if there is an alarm on the control panel <ul style="list-style-type: none"> <li>• No alarm on the control panel? Please contact your i-team partner</li> </ul>
Can't reach device to control cleaning state	The Wi-Fi connection to the CO-BOTIC 65 is interrupted	<ul style="list-style-type: none"> <li>• Check connection indicator (Figure 6)</li> <li>• Force close the app and open the app again</li> <li>• If persistent check if the remote device is connected to the WiFi and the CO-BOTIC 65 is turned on</li> </ul>



## 2.3 Ignition key

The ignition key fits in the designate keyhole located underneath the steering wheel on the right side. (Figure 7, pos 1).

The ignition key has the following positions:

- 0: OFF position;
- I: ON position;
- M: Manual activation trigger.

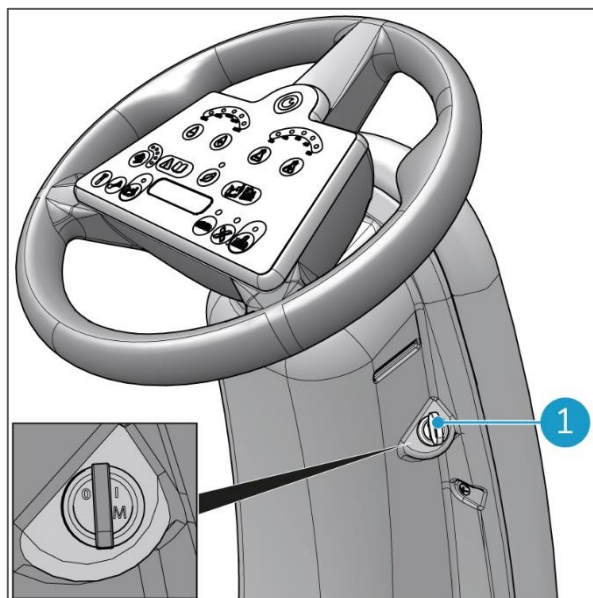

Figure 7

## 2.4 Solution level indicator

The optical solution level indicator is situated on the solution tank (Figure 8, pos 1) underneath the seat. This ensures that the solution level in the tank can be checked during filling of the tank. The floating switch inside the tank avoids that the pump runs dry. When it is activated, all cleaning functions of the CO-BOTIC 65™ stop. You are still able to drive it manually.

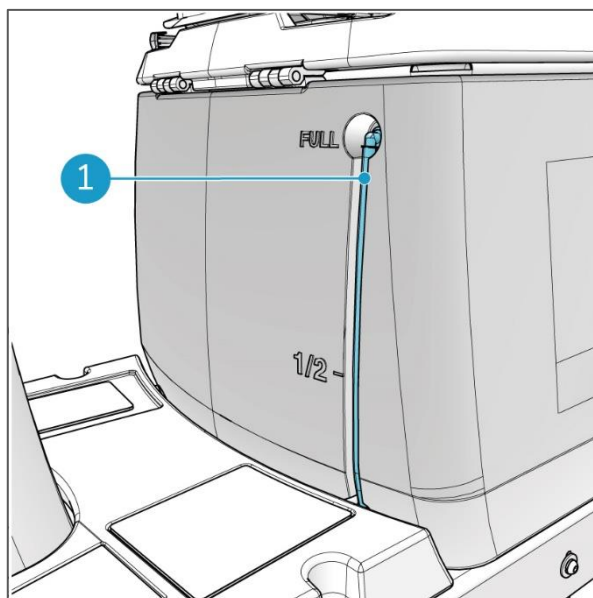

Figure 8

## 2.5 Different types of squeegee blades

You can order rubber blades or polyurethane blades for the squeegee, depending on the type of surface that you are going to clean with the CO-BOTIC 65. For more information, please visit [www.i-teamglobal.com](http://www.i-teamglobal.com).

## 2.6 Disc brushes and pads

You can order disc brushes or pads. Brushes can be used to clean most types of surfaces. Pads are used in situations in which a low noise level is required, like offices and hospitals. For more information, please visit [www.i-teamglobal.com](http://www.i-teamglobal.com).



## 2.7 Cleaning agent

You can use different foam reducing cleaning agents for different purposes. For instance, to kill bacteria, for nonfood or for an extra shiny effect. For more information, please visit [www.i-teamglobal.com](http://www.i-teamglobal.com).

## 2.8 Safety features on the CO-BOTIC 65™



### ATTENTION

The safety functions regarding the automatic mode are not active in manual mode. Avoiding obstacles and individuals is the operator's responsibility driving the machine manually.

### 2.8.1 Emergency stop

The emergency stop is triggered by:

- Activation of the operator present control, while in automatic mode;
- the emergency button (Figure 9, pos 1) positioned on both the sides.
- safety laser scanner detection (while in automatic mode)

The emergency stop means:

- the movement of the CO-BOTIC 65 is interrupted;
- the power of all actuators is cut off;
- the controller system is still under power;
- when the emergency button is deactivated the CO-BOTIC 65 can continue working, see section 2.8.3.

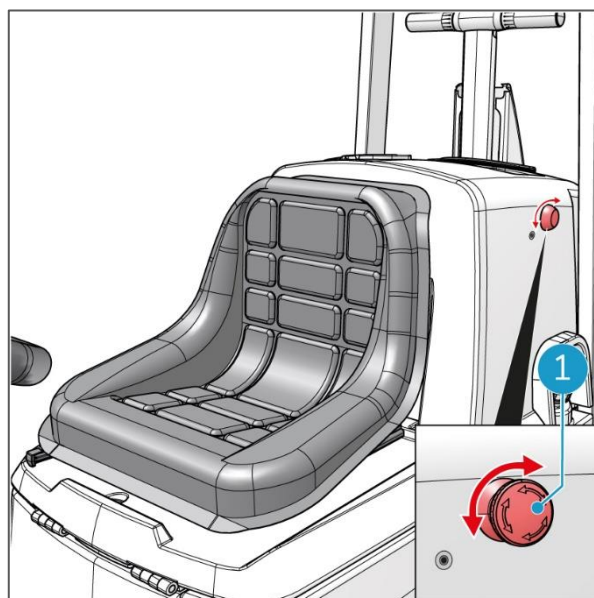

Figure 9

### 2.8.2 Emergency cut-out

The emergency cut-out is triggered by:

- the emergency cut-out button (Figure 10, pos 1) on the steering column.

The emergency cut-out means:

- the power is switched off;
- the machine shuts down completely;
- no light indications;
- no feedback on the display;
- the location and route are lost (while in automatic mode);
- no messages on the phone;
- full restart required.

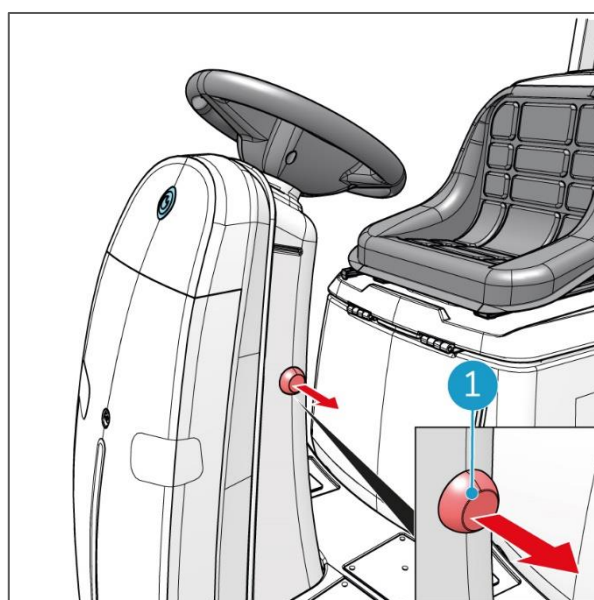

Figure 10



### **2.8.3 Emergency button**

The emergency buttons (Figure 9, pos 1) and the emergency cut-out button (Figure 10, pos 1) on the steering column can be activated by pushing the button. Deactivation of the emergency stop buttons is done by turning the button left or right. Deactivation of the emergency cut-out button is done by pulling the button out. Restart of the machine might be necessary.



## 3 Safety

Safety comes first. Therefore, please take time to read and understand these safety instructions. Improper use can cause harm or void the manufacturer's warranty.

### 3.1 General safety instructions

#### 3.1.1 Sweep before scrub

Remove objects from the floor that can be propelled by the rotating disc brushes. In case of fire, use a powder extinguisher instead of water. Keep all protective and safety measures in place.

#### 3.1.2 Disc brush condition

Make sure to check the condition of the disc brush before use. Check the red indicator mark before you start (Figure 11, pos 1). See section 7.4.4. Make sure the machine is completely turned off when replacing the disc brushes.

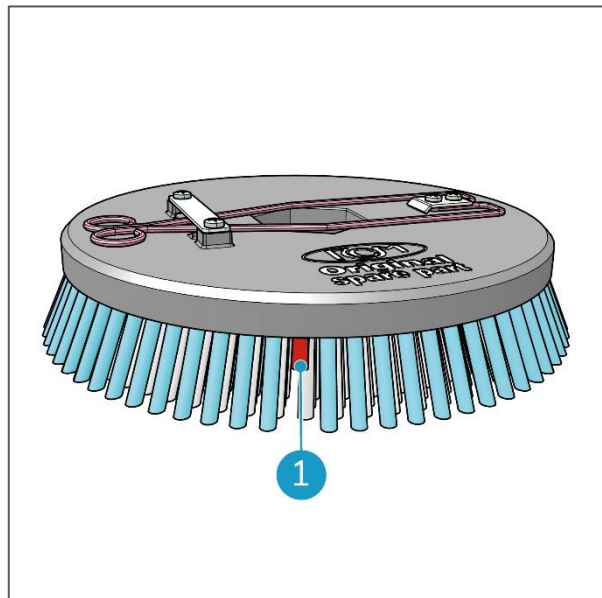

Figure 11

#### 3.1.3 Batteries

To charge the batteries, always use the automatic battery charger provided by the manufacturer.

#### CAUTION

During normal operation, the 24 V batteries in itself cause no safety hazard. Please keep in mind the following safety instructions:



- **DO NOT** crush, pierce or damage in any way;
- **DO NOT** heat or incinerate;
- **DO NOT** short-circuit;
- **DO NOT** dismantle;
- keep the batteries dry;
- keep away from sparks and flames;
- only charge between 5 °C ~ 40 °C/41 °F ~ 104 °F;
- only use between 5 °C ~ 40 °C/41 °F ~ 104 °F.



### 3.1.4 Safety laser scanner

When the safety laser scanner is damaged it needs to be replaced immediately. Contact your local i-team partner.



#### CAUTION

- **DO NOT** modify or disassemble the safety laser scanner;
- **DO NOT** look directly into or stare at the laser beams without wearing protective laser safety glasses;
- pay attention to the laser safety regulation IEC 60825-1 (latest version).

## 3.2 Risks during operation

### 3.2.1 Dress adequately

Do not wear a necktie, scarf, or any loose or dangling clothing or jewelry while operating the CO-BOTIC 65™. These can tangle in rotating parts, causing serious injury or death.

### 3.2.2 Mark the job site

The CO-BOTIC 65 is designed to leave a dry floor without slippery patches, no additional drying is required. When running the CO-BOTIC 65 with the vacuum function "OFF", please mark the job site with a wet floor marker.



#### CAUTION

Marking the jobsite with a wet floor marker is not required when using the vacuum function of the CO-BOTIC 65, unless this is a mandatory work safety requirement by local law. When unsure, mark the job site to warn passersby.

### 3.2.3 Careful when parking

Do not park the CO-BOTIC 65 on ramps or slopes. Always park the CO-BOTIC 65 on a level, hard surface.

## 3.3 Risks during automatic operation



#### CAUTION

Check the jobsite for objects that may interfere with the route. Keep the size of the entire machine in mind when looking for standing, hanging objects and objects sticking out. Also consider objects that could fall down.

## 3.4 Risks after operation

### 3.4.1 Remove battery packs

It is best practice removing the batteries before executing any cleaning or maintenance task or before storage. Charge the batteries for next use.



## 4 Transport and storage

### 4.1 General

Before storage or transport, drain and clean the machine.

### 4.2 Transport outside

Make sure you have a clear and even driving surface between buildings.



#### CAUTION

The machine can navigate a wheelchair ramp of less than 10% when the bumper and safety laser scanner are removed by a service partner. The machine cannot turn around tight corners.

### 4.3 Transport in a vehicle



#### WARNING

**DO NOT** use the i-mop bar or plastic parts of the CO-BOTIC 65™ to secure it during transport. It will damage the CO-BOTIC 65.

You can transport your CO-BOTIC 65 using a truck equipped with a loading ramp with a <math><18\%</math> slope if the bumper and the safety laser scanner are removed by a service partner. Make sure the machine is safely secured.

1. Make sure both tanks are empty.
2. Drive the machine up the loading ramp.
3. Turn off the machine.
4. Step off the machine.
5. Raise the loading ramp of the truck-bed level.
6. Turn on the machine.
7. Drive the machine into the truck.
8. Turn off the machine.
9. Secure the machine using straps or rope through the 4 holes in the chassis (Figure 12, pos 1).

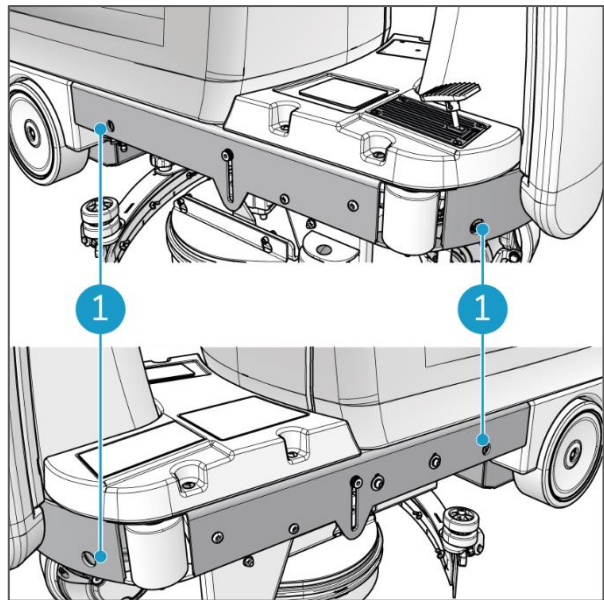

Figure 12





#### 4.3.1 Removal of bumper

1. Unscrew four screws (Figure 13, pos 1).
2. Disconnect working lights.
3. Pull the bumper (Figure 13, pos 2) in the direction of the arrow.

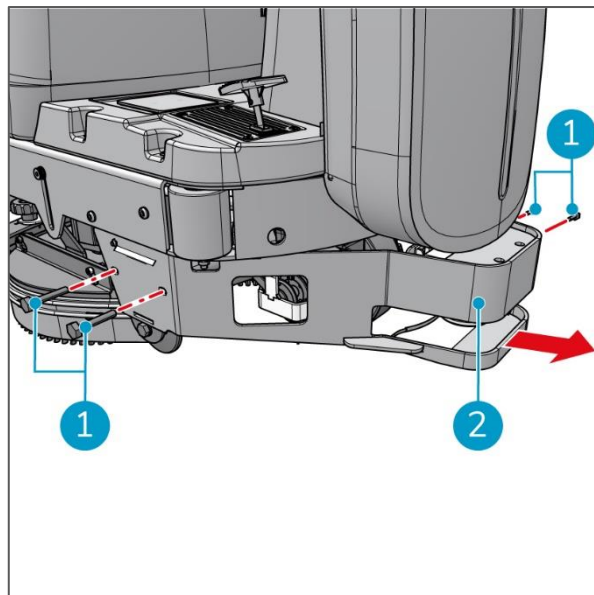

Figure 13

#### 4.4 Pushing or towing the CO-BOTIC 65™

##### WARNING



- **DO NOT** exceed a speed of 3 km/h when pushing the CO-BOTIC 65.
- **DO NOT** leave the brake released.
- after manually moving the CO-BOTIC 65 and with the electromagnetic brake engaged again, push the machine to check that the brake is actually enabled and properly functioning.
- never turn on the CO-BOTIC 65 during the time the electromagnetic brake is released.

The electromagnetic brake is integrated in the front wheel. It allows the CO-BOTIC 65 to brake.

The electromagnetic brake must be released when the CO-BOTIC 65 cannot be used due to low battery level or because there are no batteries or other causes.

In case you need to move the CO-BOTIC 65 by hand, push the red lever (Figure 14, pos 1) forward to unlock the brake.

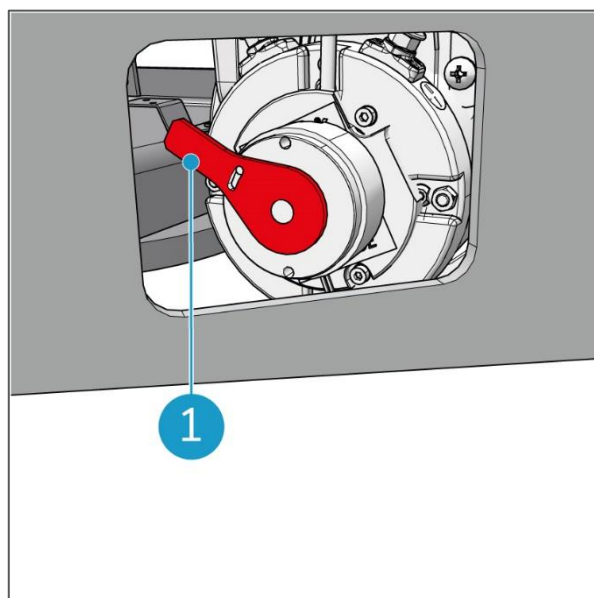

Figure 14



## 5 Assembly and installation

The CO-BOTIC 65™ comes fully assembled. Most importantly, you will have to:

1. Attach the disc brushes and brush covers.
2. Attach the squeegee.
3. Insert the batteries.
4. Load the i-mop® lite. Please refer to the i-mop lite manual for assembly instructions.

### 5.1 Unboxing

The CO-BOTIC 65 comes in a single delivery. The i-mop® lite is delivered separately in a box. The remote device is delivered separately by the i-team partner and will be set-up by the i-team partner. The safety laser scanner is delivered separately as it has specific transport instructions and will be assembled by the i-team. The batteries and the charger are also delivered separately as they can also be used for other i-team products.

#### 5.1.1 Contents of the delivery

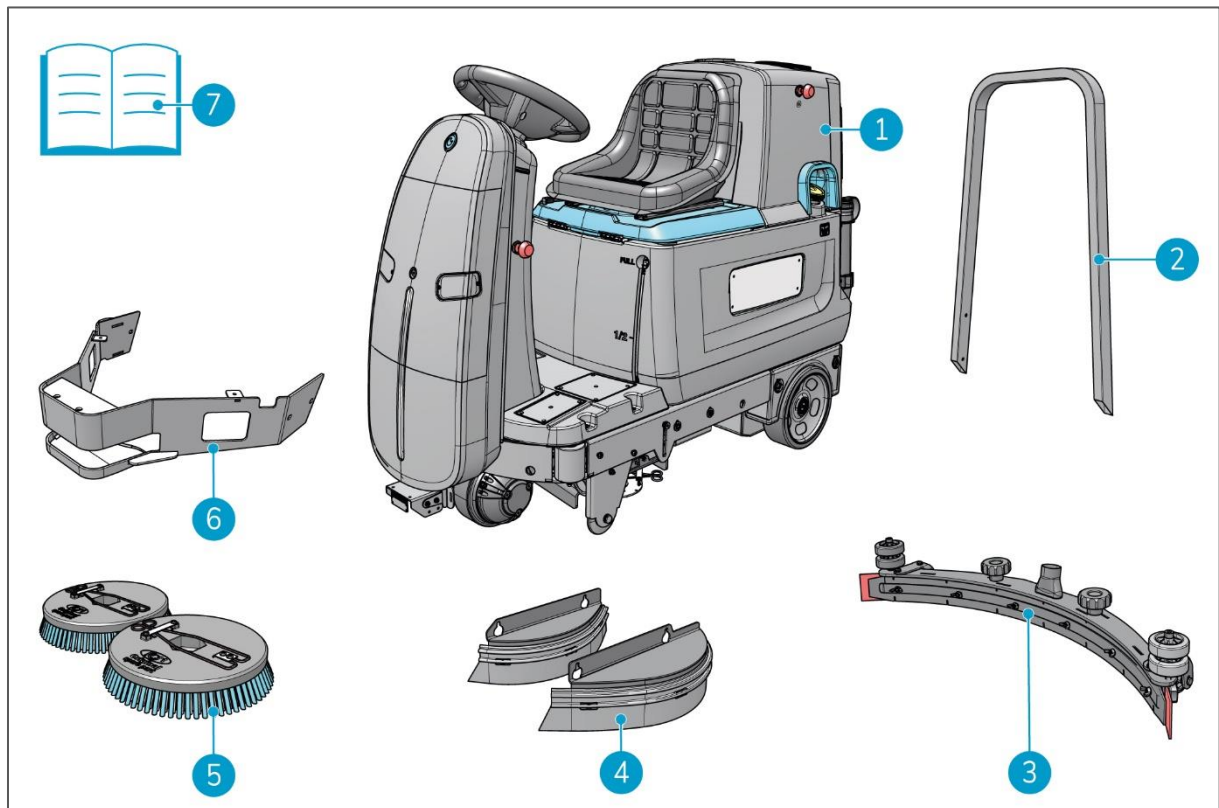

Figure 15

#### Legend

- |                         |                    |
|-------------------------|--------------------|
| 1. 1x CO-BOTIC 65       | 5. 2x disc brushes |
| 2. 1x i-mop bar         | 6. 1x bumper       |
| 3. 1x squeegee assembly | 7. 1x this manual  |
| 4. 2x brush covers      |                    |



## 5.2 Assembly

### 5.2.1 Attaching the disc brushes and brush covers

Please see section 7.4.2.

### 5.2.2 Attaching the squeegee

Please see section 7.3.2.

### 5.2.3 Inserting the batteries

Please see section 6.1.2.

### 5.2.4 Load the i-mop® lite

Please see section 7.8.1

### 5.2.5 Link the remote device

Please refer to the remote device manual for installation instructions.



## 6 Operation



### ATTENTION

Although the tanks in the CO-BOTIC 65™ have been carefully cleaned before it is packed, small amounts of plastic debris could be found during the first hours of operation.

### 6.1 Before you start

Check the disc brushes (see section 7.4.4) and squeegee (see section 7.3.3) for wear and tear.

#### 6.1.1 Adjusting the seat

1. Take place on the seat behind the steering wheel.
2. Pull the seat lever sideways (Figure 16, pos 1).
3. Move the seat (Figure 16, pos 2) backward- or forward until you are comfortable behind the steering wheel.

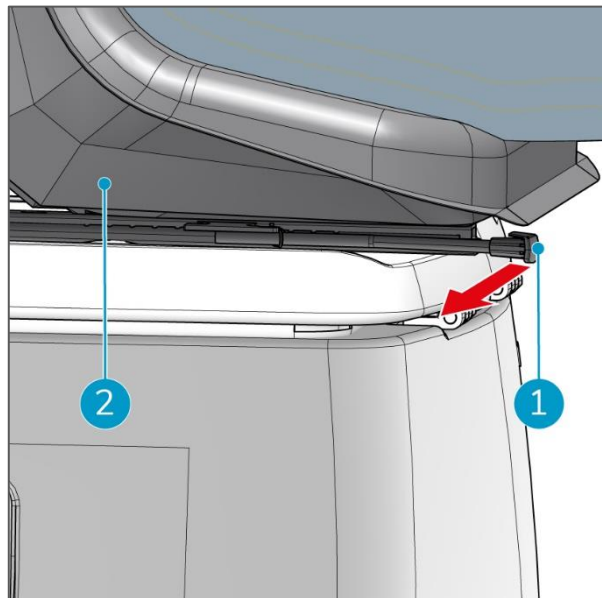

Figure 16

#### 6.1.2 Inserting the batteries

The battery drawer is located at the back of the CO-BOTIC 65.



### ATTENTION

It is recommended to fully charge the batteries before inserting them into the CO-BOTIC 65. How to charge the batteries, see User Manual i-charge® 9.



### ATTENTION

The batteries with the blue clips are all placed on the left side and the batteries with the grey clips are all placed on the right side.

1. Turn the ignition key to the OFF position and keep the key with you.
2. Pull out the locking pin on the left side (Figure 17, pos 2) of the battery drawer.
3. Pull out the battery drawer by the black handle (Figure 17, pos 1), until it locks into place.

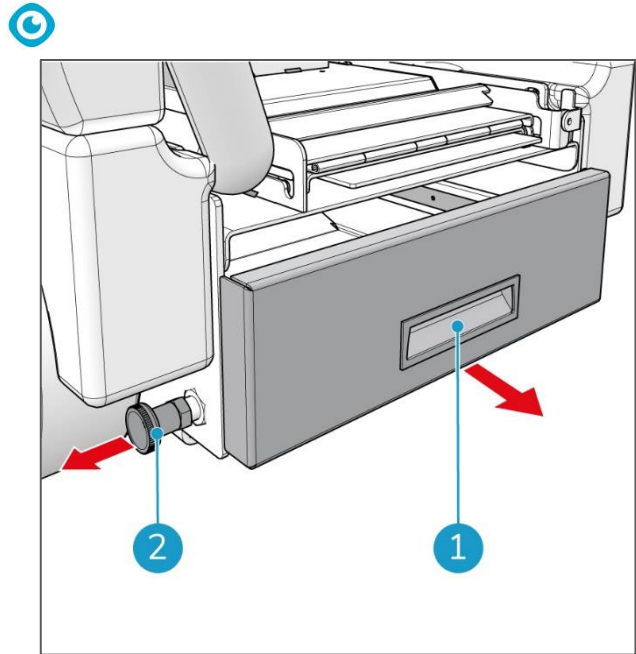

Figure 17

4. Place the batteries in the battery drawer. When they "click", they are locked into place (Figure 18, pos 1).

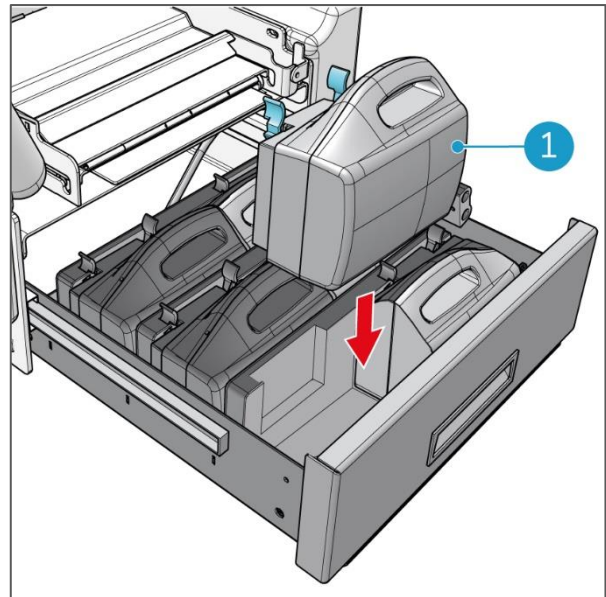

Figure 18

5. Pull out the locking pin on the left side (Figure 19, pos 2) of the battery drawer.
6. Push the battery drawer into the CO-BOTIC 65™ by the black handle (Figure 19, pos 1) until it locks into place.

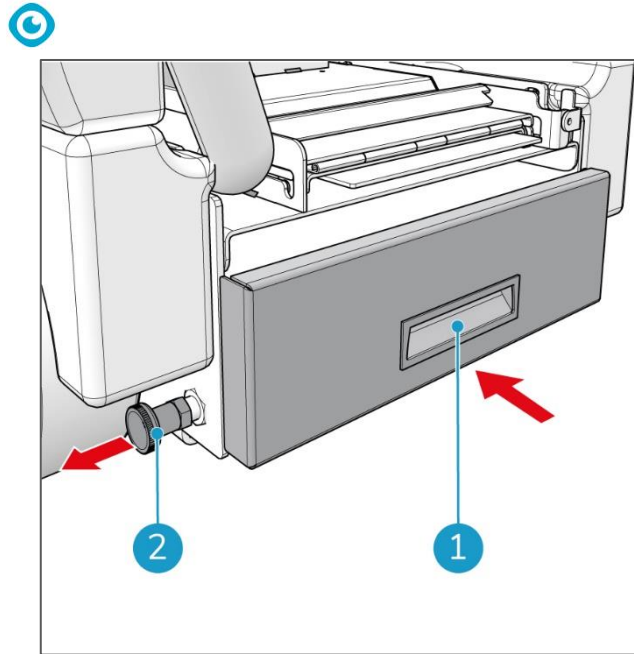

Figure 19

7. Turn the ignition key to the ON position.
8. Wait a few seconds. The display should indicate 100% and all 10 bars of the battery level display should be visible (Figure 20, pos 1).

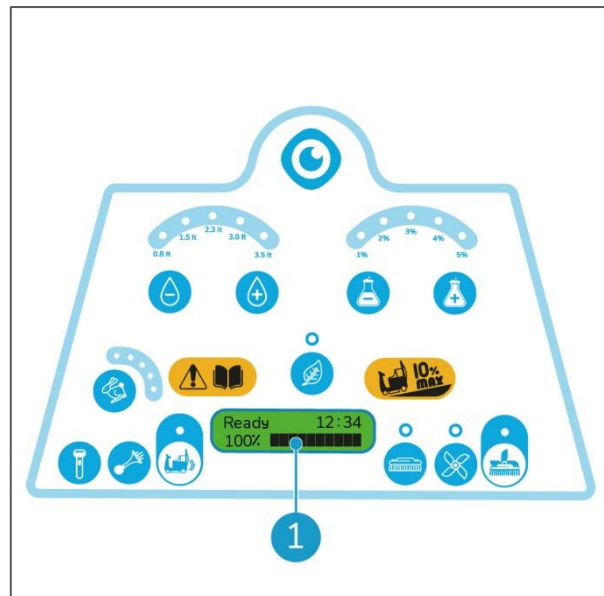

Figure 20

### 6.1.3 Filling the detergent tank



#### CAUTION

Wear protective gloves and protective glasses when filling the detergent tank.



#### ATTENTION

For specific cleaning tasks there are different cleaning agents. See section 2.7.

1. Remove the detergent tank and put it on a flat surface.
2. Open the yellow filler cap (Figure 21, pos 1).
3. While holding the handle and filler cap, pour in a maximum of 5.5 L of cleaning agent, using a funnel.
4. Replace the filler cap and make sure it seals tight.
5. Put the detergent tank back in the CO-BOTIC 65™, valve first and the handle facing towards you.
6. Clean your hands afterwards.

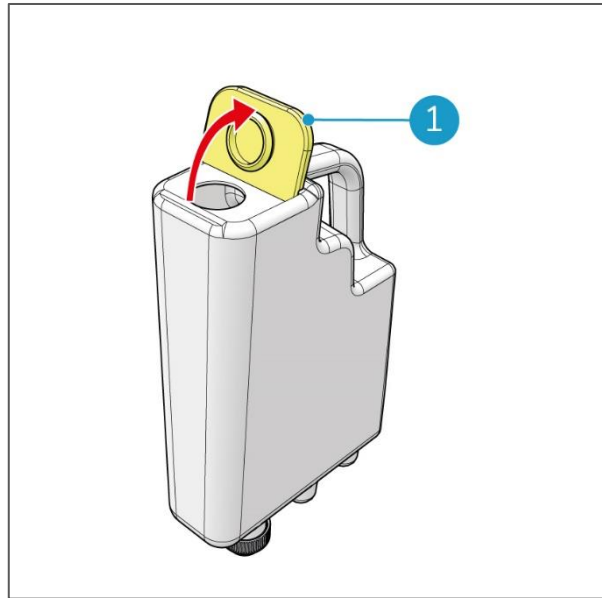

Figure 21

#### 6.1.4 Filling the solution tank

1. Remove the yellow filler cap (Figure 22, pos 1).

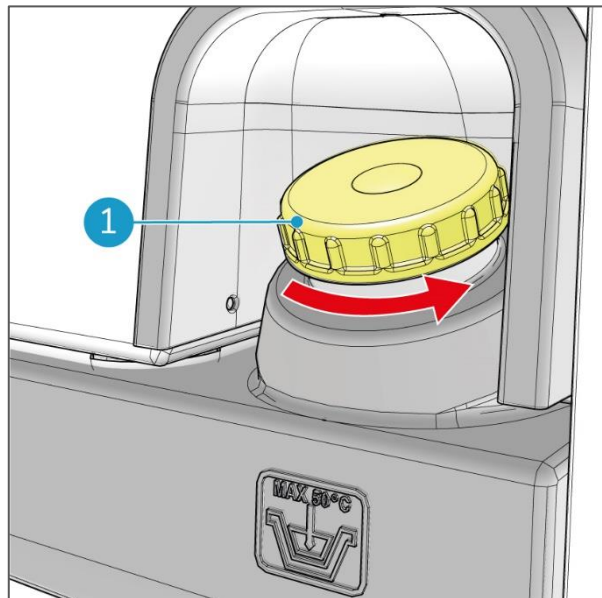

Figure 22

2. Place a water hose in the opening (Figure 23, pos 2).
3. While keeping an eye on the solution level indicator (Figure 23, pos 1), fill the tank with a maximum of 58 L of water.
4. Replace the yellow filler cap and make sure it seals tight.

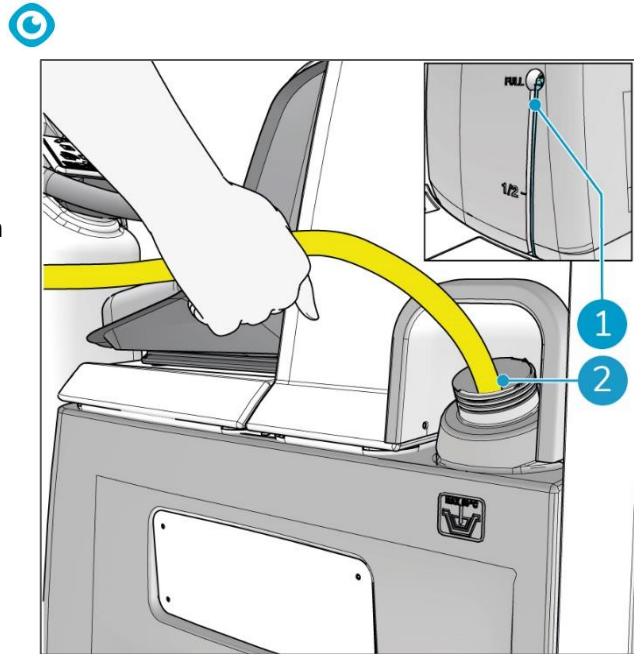

Figure 23

#### 6.1.5 Checking the solution level



#### **ATTENTION**

It is important to check the solution level regularly as the CO-BOTIC 65™ will shut down the squeegee and disc brushes if the solution level gets to 20%.

The solution level can be checked visually on the solution level indicator, which is situated on the solution tank (Figure 8, pos 1) underneath the seat. See section 2.4.





## 6.2 Operation procedure manual mode

### 6.2.1 Driving manual on the jobsite

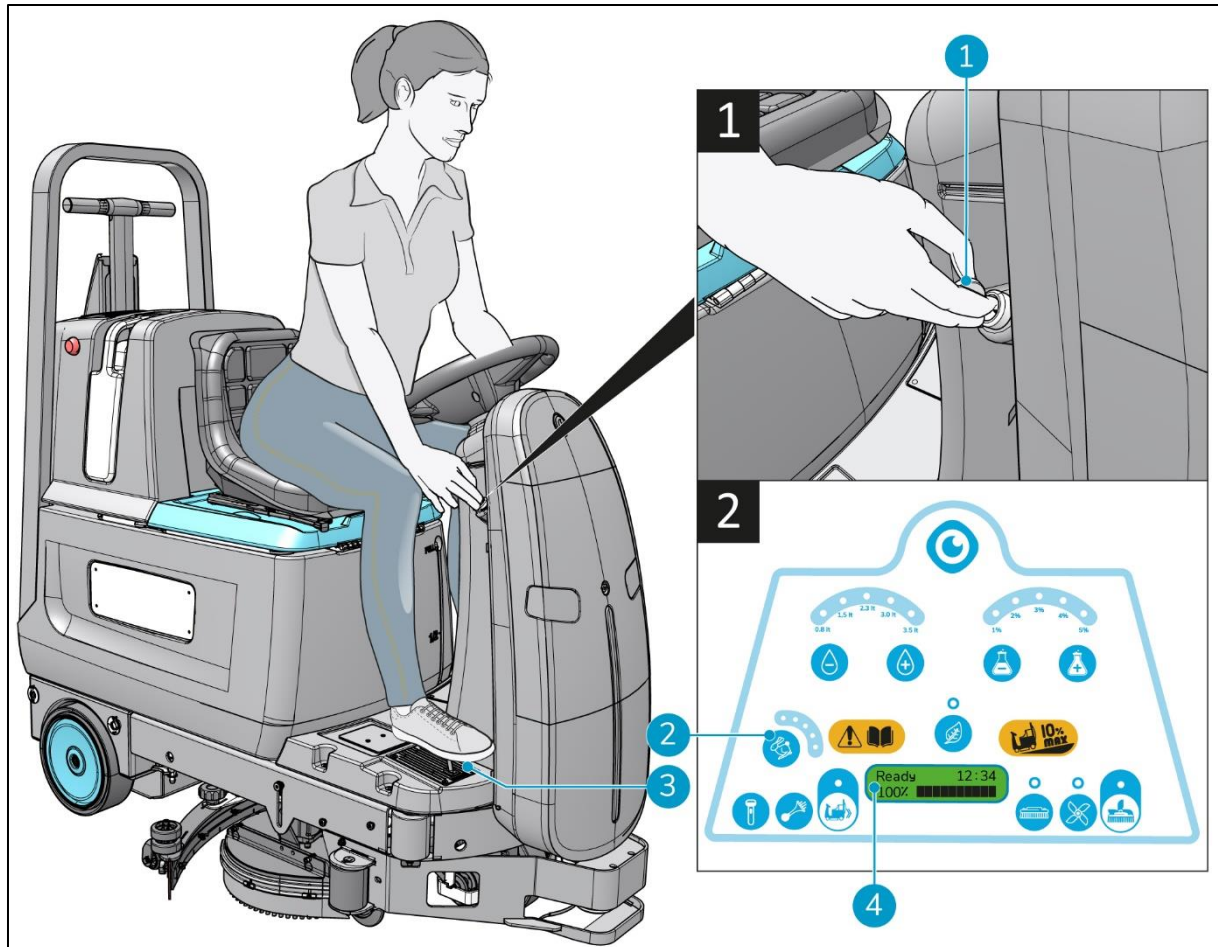

Figure 24



#### CAUTION

Make sure you have enough capacity left for the job to do. At 20% capacity the machine shuts down the squeegee and disc brush function. At 10% capacity the machine shuts down.



#### CAUTION

**DO NOT** push the accelerator pedal before start-up sequence is finished.

1. Take place on the seat behind the steering wheel. The CO-BOTIC 65™ is designed to run only in manual mode when an operator is sitting on the seat.
2. Turn the ignition key to the ON position. The dashboard lights up and a start up sound is heard.
3. Check the display for the start-up sequence to finish, it will show "Ready" (Figure 24, pos 4).
4. Check the battery level.
5. Choose the desired driving speed: 1 (up to 2.5 km/h), 2 to 5 (2.5 to 4.5 km /h) (Figure 24, pos 2).
6. Gently push the accelerator pedal down (Figure 24, pos 3) to move forward.
7. Lift your feet off the accelerator pedal to brake, the automatic break will stop the machine.



## CAUTION

Take some time to get acquainted with the handling of the machine, note the smaller left turning circle compared to turning right.

### 6.2.2 Using reverse drive



## ATTENTION

Reverse drive is only available in manual mode. When the machine drives in reverse, a reverse signal is given.

1. Make sure the CO-BOTIC 65™ is stopped and your foot is off the accelerator pedal.
2. Make sure the CO-BOTIC 65 is in manual mode. If needed, turn the ignition key to trigger the Manual position.
3. Press the reverse touch button (Figure 25, pos 1) to select reverse drive.
4. Gently push the accelerator pedal to move backwards.

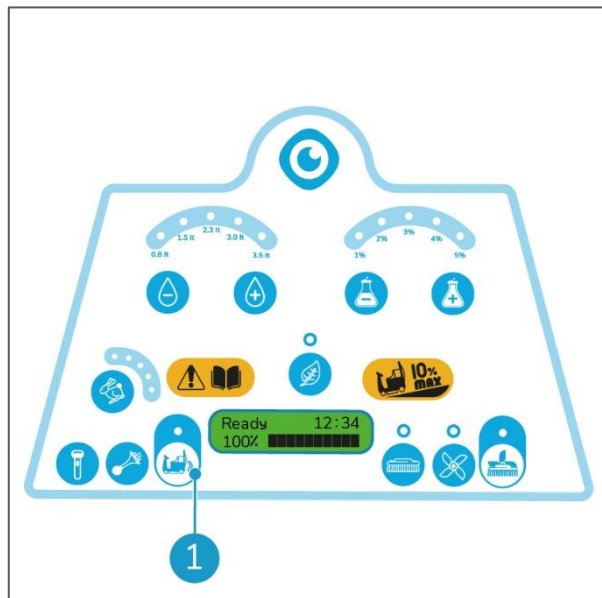

Figure 25

### 6.2.3 Using the horn

1. Push the horn button (Figure 26, pos 1) to sound the horn.

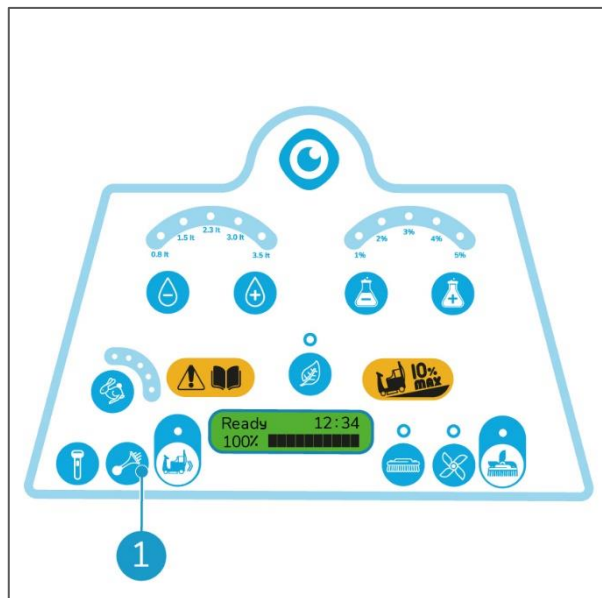

Figure 26



## 6.2.4 At the job site manual mode

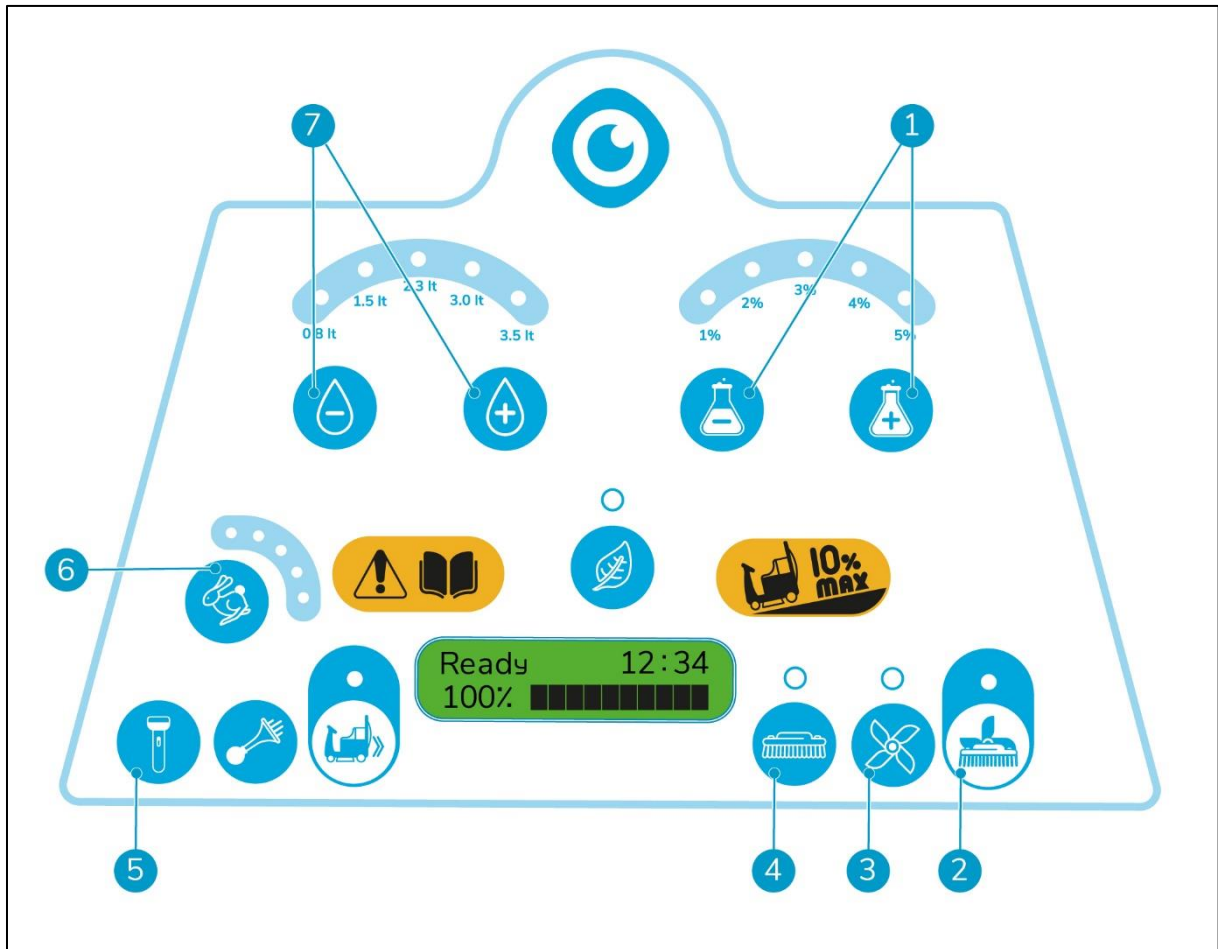

Figure 27

1. Choose the amount of water to use. Push the water touch buttons (Figure 27, pos 7) for more or less water. There are five different levels, see section 2.1.
2. Choose the amount of detergent to use, the level is always proportional to the amount of water.
3. Push the detergent touch buttons (Figure 27, pos 1) for more or less detergent. There are five different levels, see section 2.1.
4. Choose the operating mode;
  - disc brush motor ON/OFF (Figure 27, pos 4) or;
  - vacuum motor ON/OFF (Figure 27, pos 3) or;
  - disc brush and vacuum motor ON/OFF (Figure 27, pos 2).
5. Turn on the working lights (Figure 27, pos 5).
6. Choose your speed (Figure 27, pos 6).
7. Gently press the accelerator pedal to start cleaning.



### ATTENTION

The water level/detergent level and speed depend on the amount of dirt and smoothness of the floor. Driving at slow speed will improve cleaning performance using less detergent and water.



### 6.2.5 Working in ECO mode

The ECO mode (Figure 28, pos 1) will slow down the machine as well as reduce the usage of water and solution. See section 2.1.

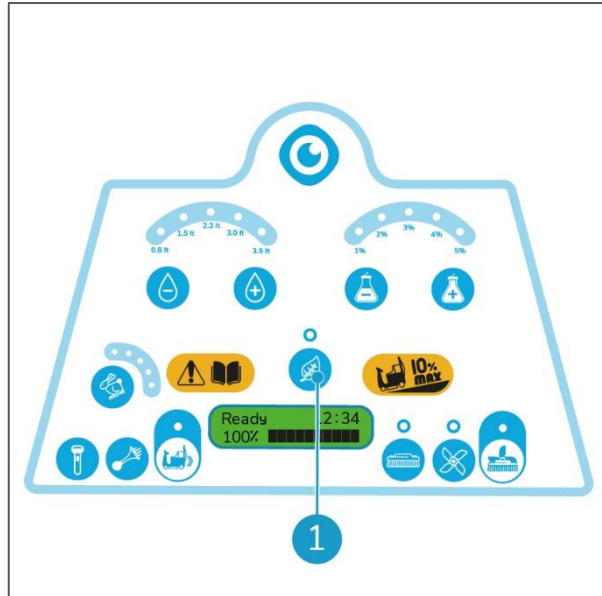

Figure 28

## 6.3 Operation procedure automatic mode

### 6.3.1 Checking the remote device



#### ATTENTION

It is recommended to fully charge the batteries of the remote device before using the CO-BOTIC 65™ in automatic mode. How to charge the remote device batteries, please refer to the remote device manual.

1. Switch on the remote device. The login screen is displayed (Figure 29).
2. Fill in the PIN code.

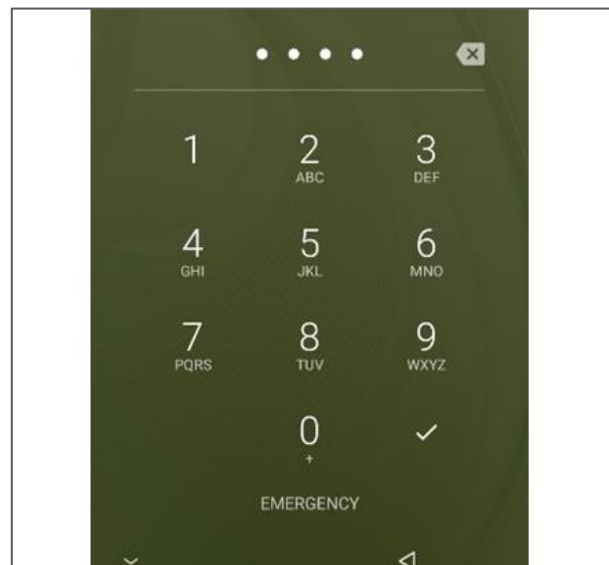

Figure 29

3. The home screen will be shown (Figure 30).
4. Choose the i-drive app.

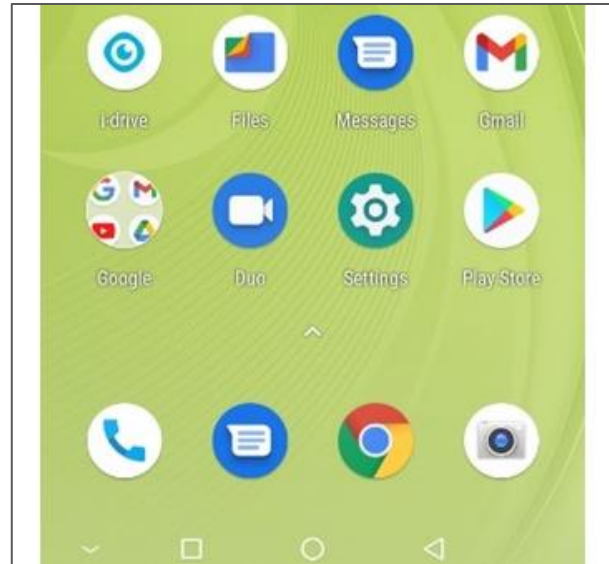

Figure 30

5. The available devices will be shown (Figure 31).
6. Choose the desired CO-BOTIC 65™. When the CO-BOTIC 65 starts up, the CO-BOTIC number and the IP number are shown on the display on the steering wheel for a few seconds. The IP number should also be available next to the identification sticker.
7. The operating screen will open (Figure 6).

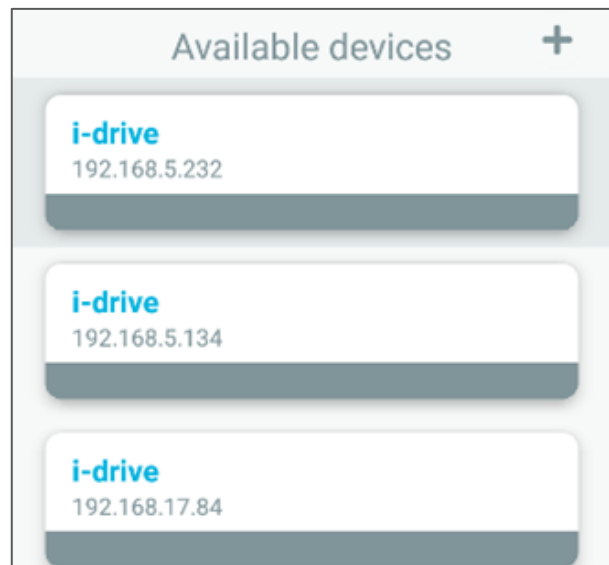

Figure 31



### 6.3.2 Driving automatic on the jobsite



#### CAUTION

Make sure you have enough capacity left for the job to do. At 20% capacity you can not start automatic mode. When reaching 20% capacity during use, the CO-BOTIC 65™ shuts down the squeegee and disc brush function and the automatic mode will stop. The CO-BOTIC 65 should then be driven manually to the battery charger.



#### CAUTION

Make sure the route is clear of any objects. Keep the size of the entire machine in mind when looking for standing, hanging objects and objects sticking out. Also consider objects that could fall down.

**DO NOT** sit on the CO-BOTIC 65 while in automatic mode.

1. Take place on the seat behind the steering wheel. The CO-BOTIC 65 is designed to run only in manual mode when an operator is sitting on the seat.
2. Turn the ignition key to the ON position. The CO-BOTIC 65 makes a sound and the dashboard lights up.

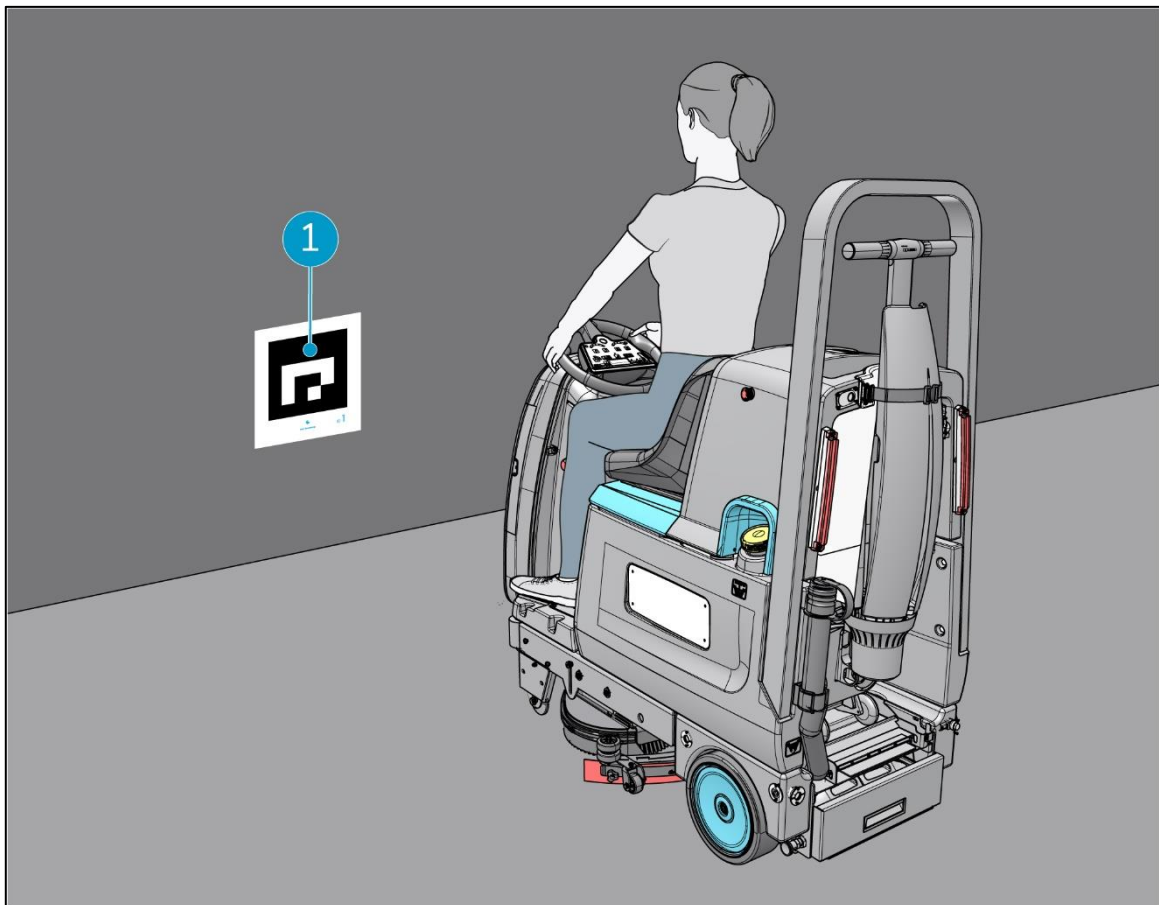

Figure 32



3. Check the display for the start-up sequence to finish, it will show "Ready".
4. Check the connection indicator on the remote device (Figure 35, pos 1).
5. Check the battery level (Figure 35, pos 6).
6. Drive the CO-BOTIC 65™ to a location marker (Figure 32).
7. The CO-BOTIC 65 must be placed at a distance between 1 and 2.5 meters in front of the location marker (Figure 33).

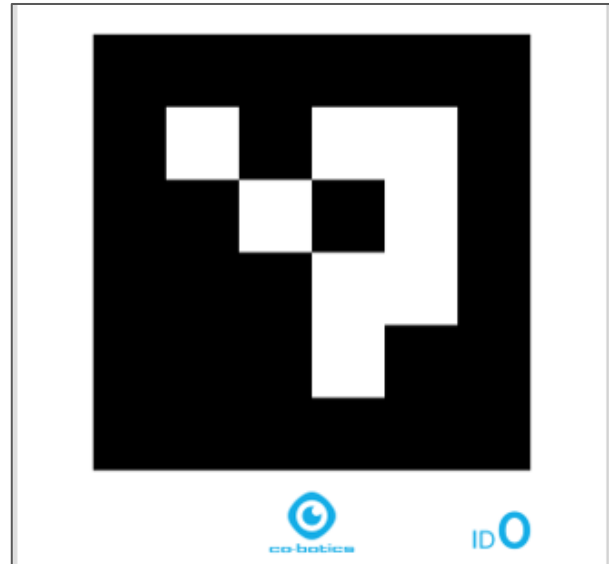

Figure 33

8. The localization is successful when the location indicator turns green and the CO-BOTIC 65 makes a sound.
9. Drive the CO-BOTIC 65 to the start point marker (Figure 34) of the desired route. As programmed and instructed by the service partner.
10. Step off the CO-BOTIC 65.
11. On the remote device choose the correct route (Figure 35, pos 4), select the cleaning mode (Figure 35, pos 7), adjust settings accordingly and press start (Figure 35, pos 11).

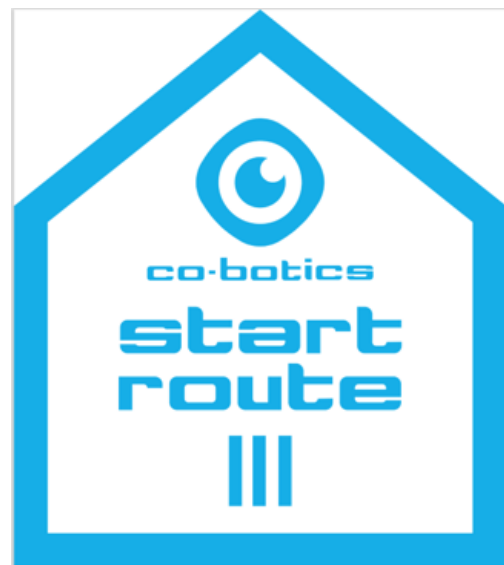

Figure 34

12. The display will show Starting i-drive. The CO-BOTIC 65 will calibrate the steering wheel, if needed, and will start the route automatically when ready. The CO-BOTIC 65 makes a sound and the lights turn on.
13. On the remote device the robot is shown (Figure 35, pos 2) and on the map (Figure 35, pos 5) the CO-BOTIC 65 can be followed digitally.
14. The CO-BOTIC 65 shows which way it is going by using the left or right direction indicator.
15. At the end of the route the display will show Cleaning route Finished. To repeat the same cleaning route turn the ignition key to trigger the Manual position for 5 seconds and start the CO-BOTIC 65 with the remote device.



### 6.3.3 At the job site automatic mode

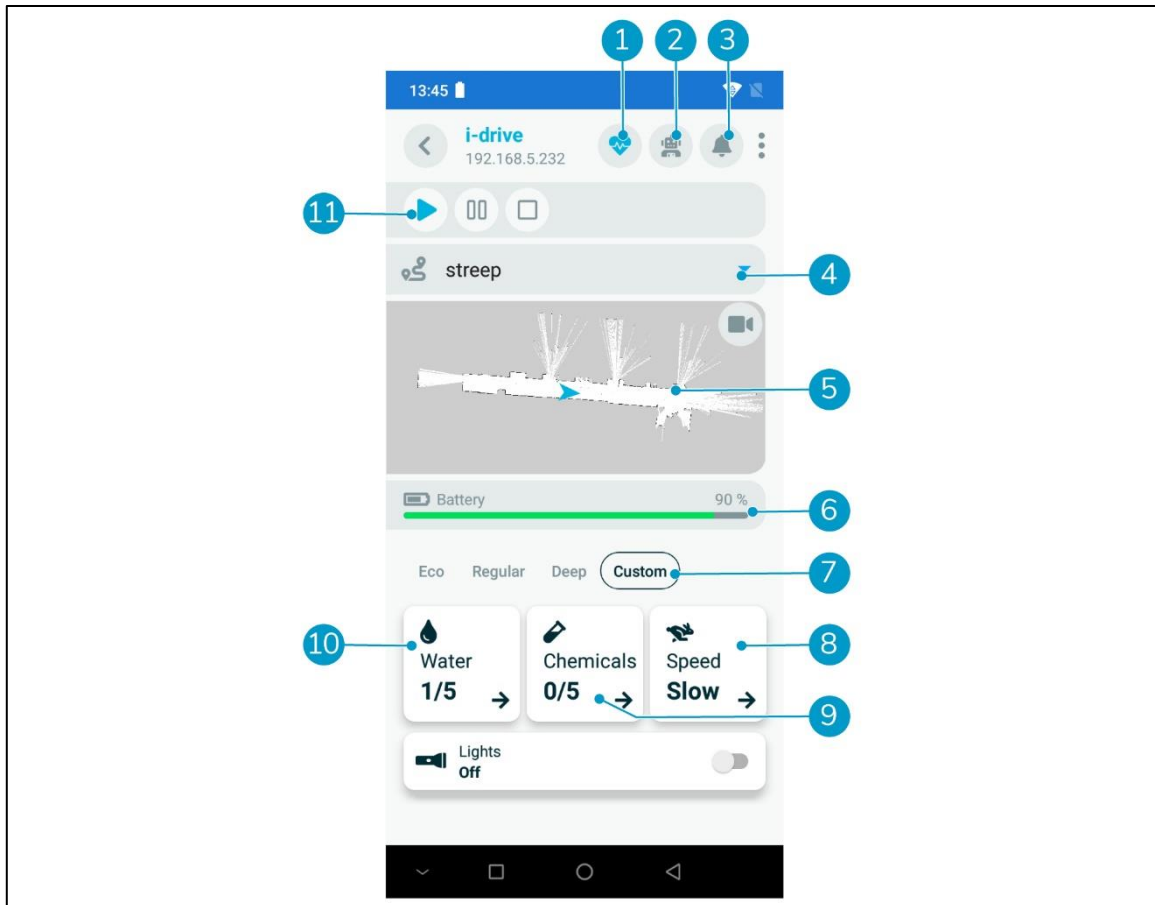

Figure 35

1. On the remote device notifications can pop up when the CO-BOTIC 65™ communicates a problem. In the app the notifications can be shown by touching the error button (Figure 35, pos 3). The CO-BOTIC 65 should be checked.
2. If the connection button (Figure 35, pos 1) is greyed out in the app, the communication is lost with the CO-BOTIC 65 and the CO-BOTIC 65 should be checked.
3. The cleaning mode can be adjusted at any time. The custom cleaning mode (Figure 35, pos 7) provides the option to:





- Choose the amount of water to use. Touch the Water button (Figure 35, pos 10) for more or less water. Choose one of the five different levels in the Water window (Figure 36). Touch the Set Water button to save.
- Choose the amount of detergent to use, the level is always proportional to the amount of water. Touch the Chemicals button (Figure 35, pos 9) for more or less detergent. Choose one of the five different levels in the Chemicals window. Touch the Set Chemicals button to save.

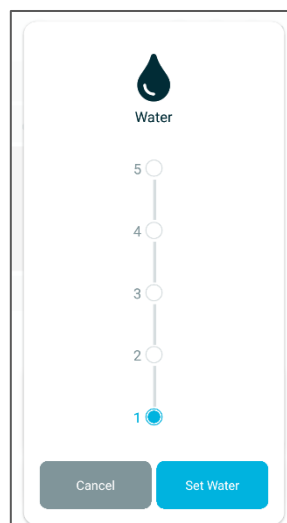

Figure 36

- Choose the speed to use. Touch the Speed button (Figure 35, pos 8) and choose Fast (up to 3.6 km/h adjusts accordingly) or Slow (1.0 km/h). Touch the Set Speed button to save.



## 7 Maintenance



### WARNING

Before you start maintenance or replace parts, make sure to turn off the CO-BOTIC 65™ with the ignition key and keep the ignition key with you during maintenance, unless instructed otherwise.

For a proper functioning and a long lifespan of the CO-BOTIC 65, it is important to follow the recommended maintenance intervals mentioned in this manual.

Maintenance that is not described in this manual should be performed by your CO-BOTIC 65 partner. Please make sure to have the model, serial number and the amount of operating hours of the CO-BOTIC 65 available when you call a partner. For more information, please fill out the contact form on [www.i-teamglobal.com](http://www.i-teamglobal.com).

Maintenance and assembling or disassembling of the CO-BOTIC 65 must only be done by a person who:

- has correctly read and understood the instructions in this manual;
- is qualified;
- is trained by an experienced operator who has read and understood the instructions in this manual;
- is an adult person;
- is a supervisor (for specific maintenance tasks).

### 7.1 Cleaning the CO-BOTIC 65



### WARNING

**DO NOT** clean the CO-BOTIC 65 with a high-pressure cleaner or with corrosive substances. This can cause damage to the electrical parts of the CO-BOTIC 65.

#### 7.1.1 Cleaning the machine

Clean the exterior of the machine using a damp cloth after operating it and before storing it.

#### 7.1.2 Cleaning the safety laser scanner

Clean the exterior of the machine using a damp cloth after operating it and before storing it.

Dust covering the optical window could affect the safety laser scanner's detection capability. If the safety laser scanner is installed in a dusty environment, regular cleaning of the optical window is necessary. Depending on the level of contamination follow the cleaning method mentioned below:

- Switch off the CO-BOTIC 65 and remove the ignition key before cleaning the optical window.
- Wipe the optical window with a clean, soft cloth.
- Clean the optical window with a soft brush.
- Blow off the dust on optical window using an air-blower.
- Clean the optical window with mild detergent if it is contaminated with oil or grease particles.



### WARNING

**DO NOT** clean the safety laser scanner with abrasive cleaner or organic solvents (such as thinner, benzene and acetone). This can cause damage to the safety laser scanner resulting in the loss of detection capability.



## 7.2 Checking the machine operating hours



### ATTENTION

This maintenance task should only be done by a supervisor.

1. Take place on the seat behind the steering wheel.
1. Place the ignition key in the keyhole (Figure 37, pos 1).
2. Turn the ignition key to the ON position. The dashboard on the steering wheel lights up.

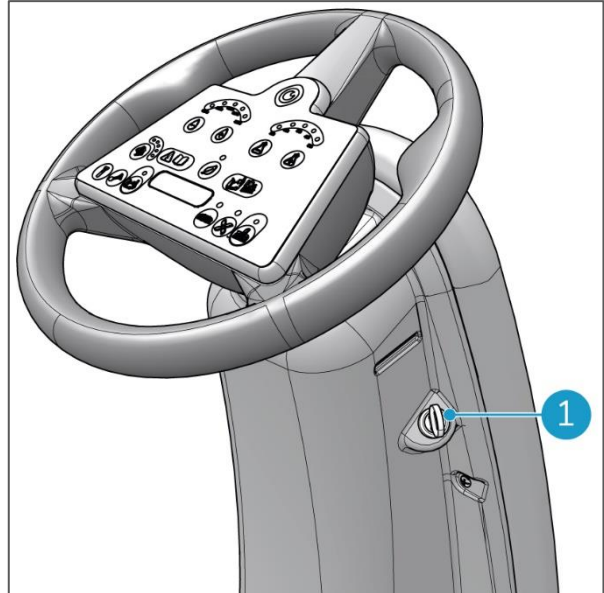

Figure 37

3. Wait until "Ready" (Figure 38, pos 2) appears on the display.
4. The amount of operating hours and minutes spent is shown in the top right corner of the display (Figure 38, pos 1).
5. Check the maintenance frequency table in section 7.13 to see which actions should be taken.
6. Turn the ignition key to the OFF position to switch off the CO-BOTIC 65™.

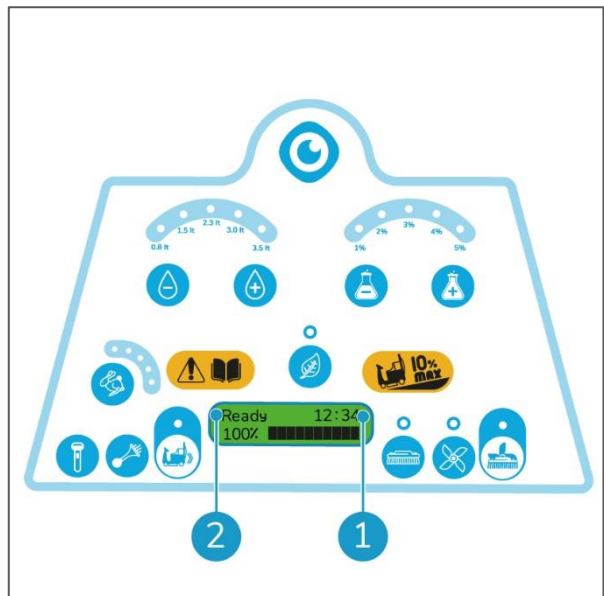

Figure 38



## 7.3 Maintenance tasks on the squeegee

### 7.3.1 Removing the squeegee body from the squeegee lifting plate



#### CAUTION

Be careful with your hands, a strong spring pushes the squeegee lifting plate down!

1. Take place on the seat behind the steering wheel.
2. Turn the ignition key to the ON position. After a few seconds the text "Ready" appears on the display (Figure 39, pos 2).
3. Press the push button (Figure 39, pos 1). The squeegee moves to its lowest position.
4. Turn the ignition key to the OFF position and remove it. Keep the key with you during maintenance.

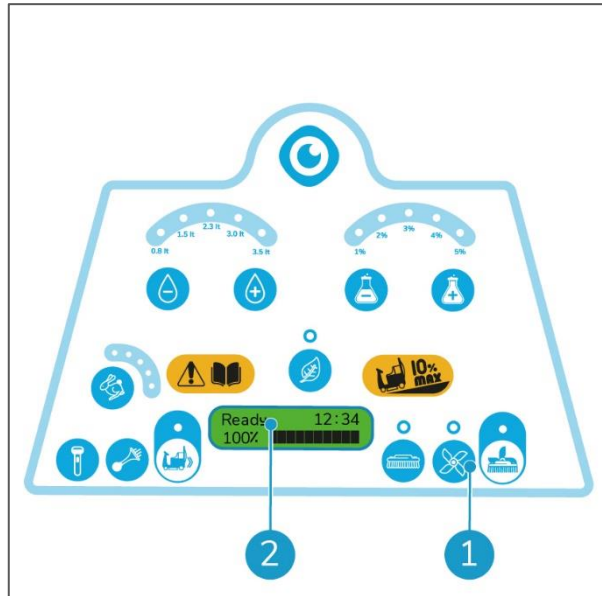

Figure 39

5. Go to the right side of the CO-BOTIC 65™.
6. Remove the vacuum hose from the hose connector (Figure 40, pos 1).
7. Loosen the two rotary knobs (Figure 40, pos 2).
8. Pull the squeegee body backwards, out of the squeegee lifting plate (Figure 40, pos 3).
9. Carefully remove the squeegee body from underneath the CO-BOTIC 65.
10. Place the squeegee body on an even surface or on the floor. It is now ready to be cleaned or maintained.

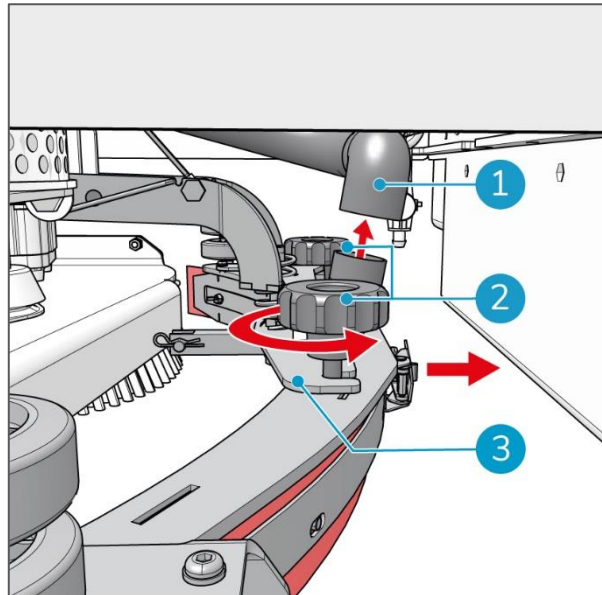

Figure 40



### 7.3.2 Placing the squeegee body back on the squeegee lifting plate

1. Position the squeegee body under the CO-BOTIC 65™, line up the rotary knobs with the cutouts in the squeegee lifting plate.
2. Lift the squeegee lifting plate.
3. Slide the rotary knob of the squeegee body, the furthest away from you (Figure 41, pos 1), into the cutout of the squeegee lifting plate (Figure 41, pos 3). Make sure to push it fully into the cutout.
4. Tighten the rotary knob hand tight (Figure 41, pos 1).
5. Repeat for the rotary knob closest to you (Figure 41, pos 2).
6. Push the vacuum hose onto the hose connector of the squeegee (Figure 42, pos 1).
7. Check that the vacuum hose fits tightly.
8. Take place on the seat, behind the steering wheel.
9. Place the ignition key back in the keyhole. Turn the ignition key to the ON position. The squeegee will move to its highest position.
10. After a few seconds the text "Ready" appears on the display (Figure 39, pos 2).

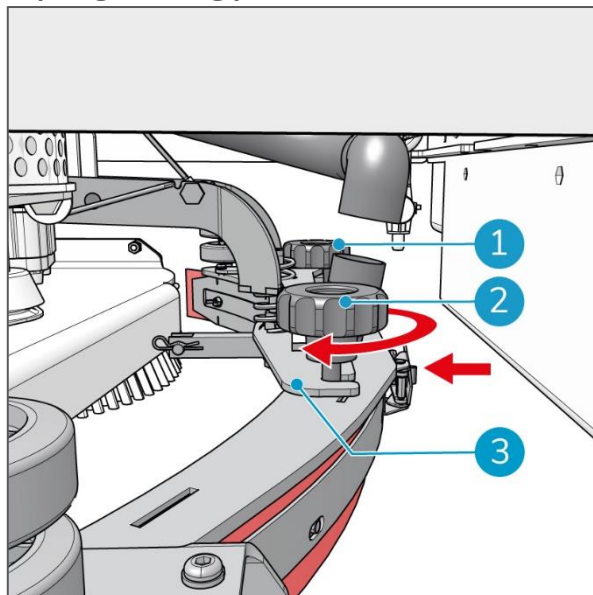

Figure 41

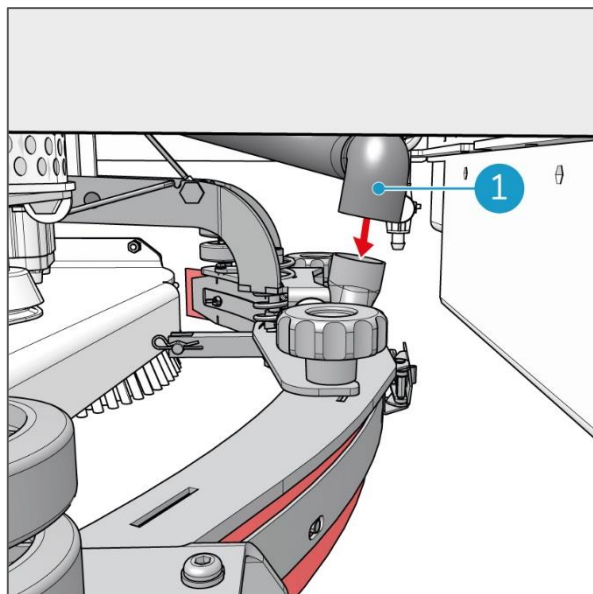

Figure 42

### 7.3.3 Cleaning, checking and replacing the squeegee blades



#### CAUTION

Wear protective gloves when cleaning the squeegee, as sharp debris may be attached to it.



#### ATTENTION

In order to dry the floor properly, the squeegee must be clean and the blades in good condition. The rear blade must have a square angle for effective cleaning.



**TIP:**

Daily cleaning can be done with the blades in the squeegee body. Clean the edges of the blades with a damp cloth. Only step 1 and step 15 need to be done.

1. To remove the squeegee body from the squeegee lifting plate of the CO-BOTIC 65™, please see section 7.3.1.

Removing the back blade (no holes).

2. Loosen the small rotary knobs at both ends of the squeegee (Figure 43, pos 1).
3. Remove the clamping plate (Figure 43, pos 2) of the back blade.
4. Remove the back blade from the squeegee frame (Figure 43, pos 3).

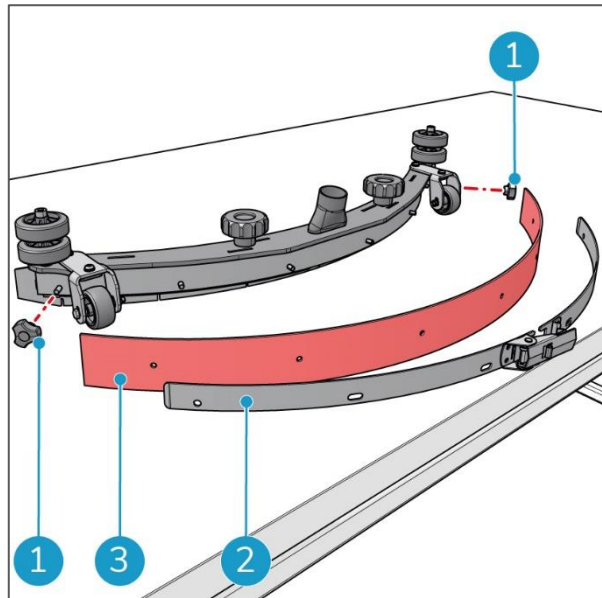

Figure 43

Removing the front blade (with holes).

5. Loosen the six wing nuts of the front blade (Figure 44, pos 2).
6. Remove the clamping plate of the front blade (Figure 44, pos 3).
7. Remove the front blade (Figure 44, pos 1) from the squeegee body.

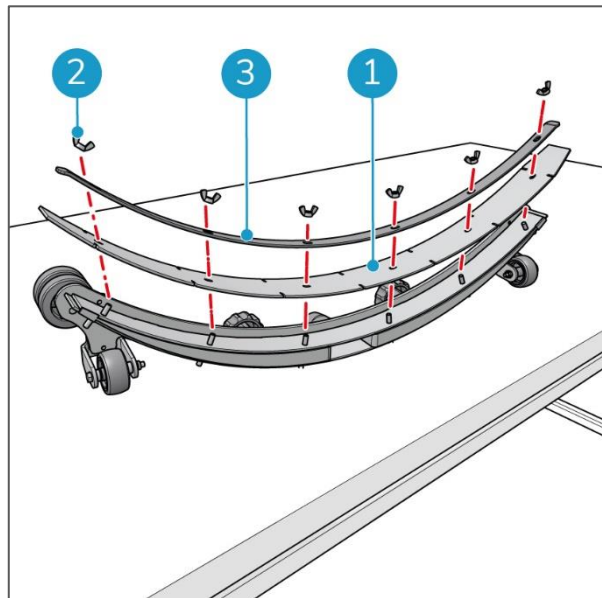

Figure 44

8. Clean the squeegee blades with tap water in a sink.
9. Carefully remove debris from the recovery water inlet (Figure 45, pos 1) by hand.
10. Check the back blade.  
The working edge of the back blade (Figure 46, pos a) must have a square angle ( $90^\circ$ ), otherwise it does not scrape efficiently. If it is worn, you can use one of the other edges (Figure 46, pos b, c, d). If all four edges are round or the back blade is damaged or torn on the top and bottom, replace it by a new one.
11. Check the front blade.  
If it is damaged or torn on the top and bottom, replace it by a new one.

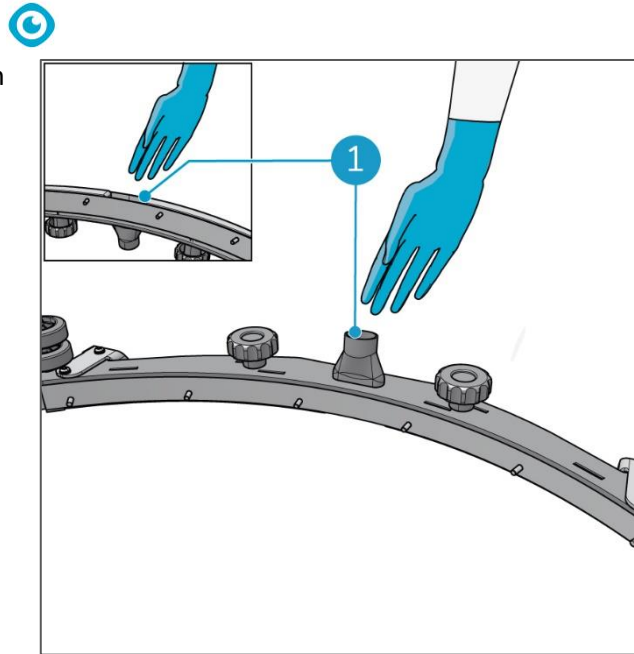

Figure 45

Placing back the back blade. See Figure 43.

12. Place the back blade and the clamping plate on the squeegee body.
13. Hold the clamping plate into place with the two small rotary knobs.
14. Lock the clamping plate.

Placing back the front blade. See Figure 44.

15. Do step 5 to 7 in reverse order, start tightening the wing nuts on one side and work to the other side.

16. To replace the squeegee body on the squeegee lifting plate of the CO-BOTIC 65™, please see section 7.3.2.

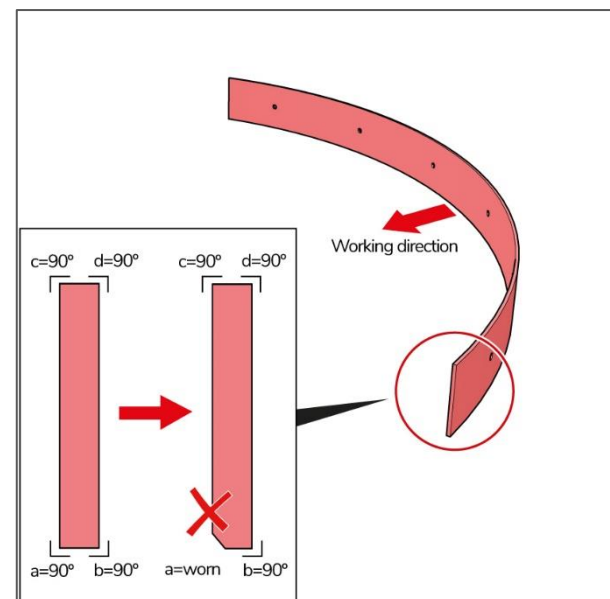

Figure 46





## 7.4 The disc brushes

### 7.4.1 Removing the disc brushes



#### ATTENTION

The supporting bolts are fixed for transportation, please check them and loosen them if they are fixed.

1. Make sure that the ignition key is in the OFF position and remove it. Keep it with you during maintenance.
2. Lift the grey brush cover a little.
3. Pull it from its supporting bolts (Figure 47, pos 1) to remove it.
4. Carefully place it on the floor or a level surface.

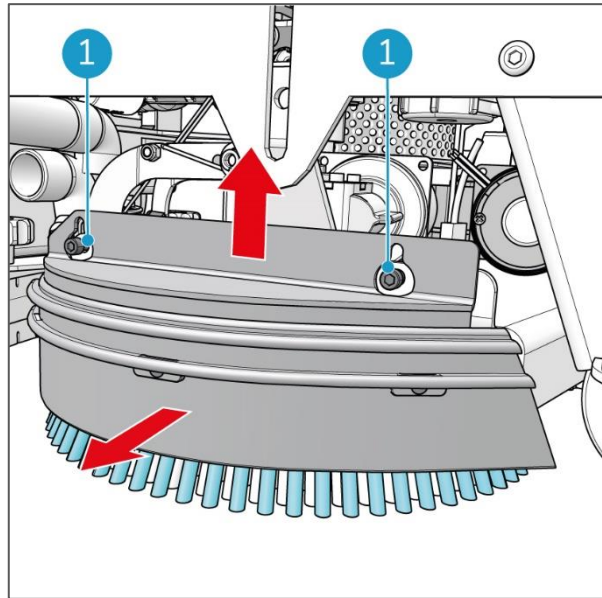

Figure 47

5. Push the two springs (Figure 48, pos 1) fully outward until they lock into place, behind the cams. The clamp is now released.
6. Carefully remove the disc brush (Figure 48, pos 2).
7. Place it on the floor or on a level surface.
5. Repeat this sequence for the second disc brush.

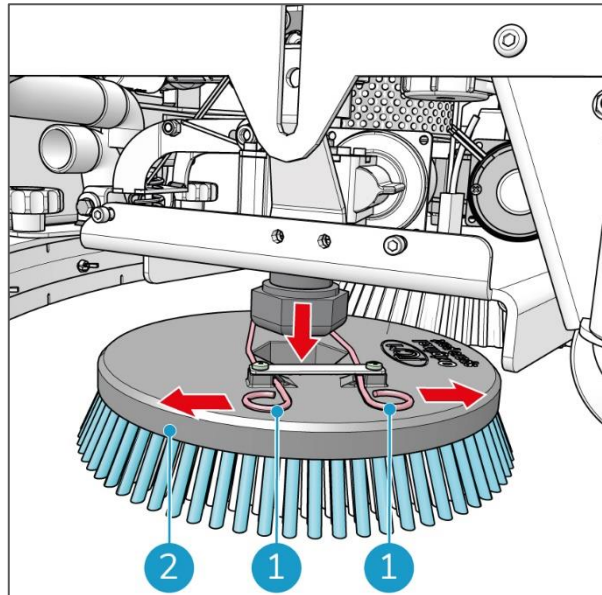

Figure 48



### 7.4.2 Placing back the disc brushes

1. Make sure that the springs (Figure 49, pos 1) are locked into place behind the cams (Figure 49, pos 2).
2. Push the disc brush on the hexagonal nut of the drive shaft (Figure 49, pos 3) and wiggle it until you feel it is in place.
3. Release the springs to lock the clamp on the hexagonal nut (Figure 49, pos 3).
4. Align the holes of the grey brush cover (Figure 47) with the supporting bolts (Figure 49, pos 4).
5. Place the grey brush cover on the support bolts, push it down to lock it.
6. Repeat this sequence for the second brush.

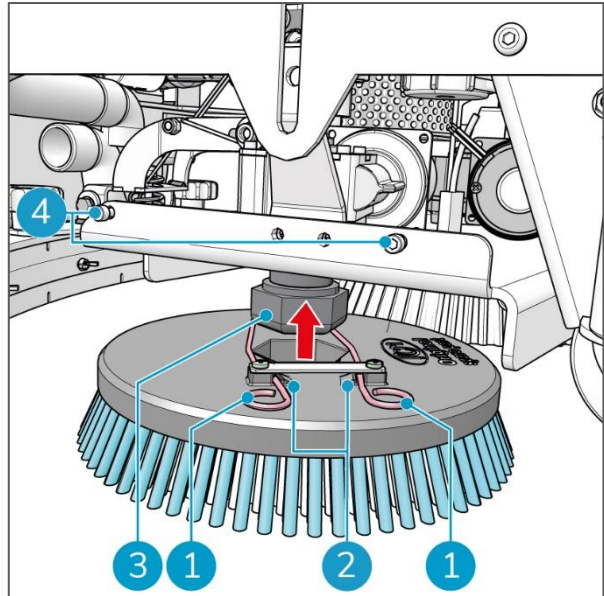

Figure 49



#### WARNING

After replacing the disc brush, check that it is secured as the discs brush rotates at high speed and a loose disc brush can cause serious harm.

### 7.4.3 Cleaning the disc brushes



#### CAUTION

Wear protective gloves when cleaning the disc brushes as sharp debris may be attached to it.

1. To remove the disc brushes, please see section 7.4.1.
2. Check both disc brushes for metal parts, debris that can damage the surface of the floor or cigarettes.
3. Carefully remove the debris from each disc brush by hand (Figure 50, pos 1).
4. To place the disc brushes back, please see section 7.4.2.

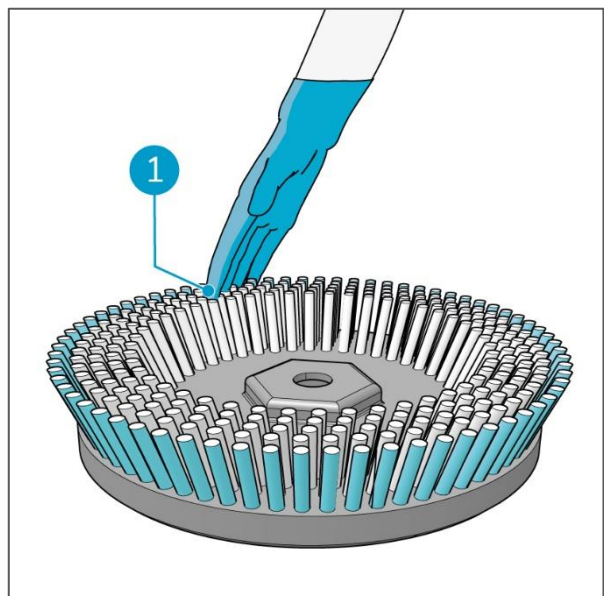

Figure 50



#### 7.4.4 Replacing the disc brushes



##### ATTENTION

Each disc brush has a wear indicator. This is the red bristle group. If the disc brush is worn near to the length of the red bristle group, it needs to be replaced.

1. To remove the disc brushes, please see section 7.4.1.
2. Check the condition of the disc brushes. If the bristle length is near the length of the red bristle group (Figure 51, pos 1), it needs to be replaced.
3. To place the disc brushes back, please see section 7.4.2.

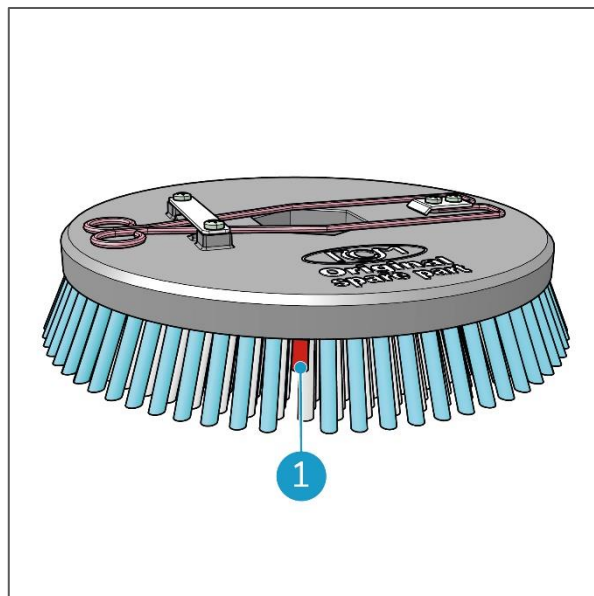

Figure 51

#### 7.4.5 Replacing the pads

1. To remove the pad drivers, please follow the same procedure as for removing the disc brushes, see section 7.4.1.
2. Check the condition of the pads (Figure 52, pos 1). If they look compressed, they lose their function and they need to be replaced.
3. Pull the pad out of the three locking tabs (Figure 52, pos 2) and remove the pad from the pad driver (Figure 52, pos 3).
4. Lock the new pad to the pad driver by pushing it with your thumbs behind the three locking tabs.
5. Repeat for the second pad.
6. To place the pad drivers back, please see section 7.4.2.

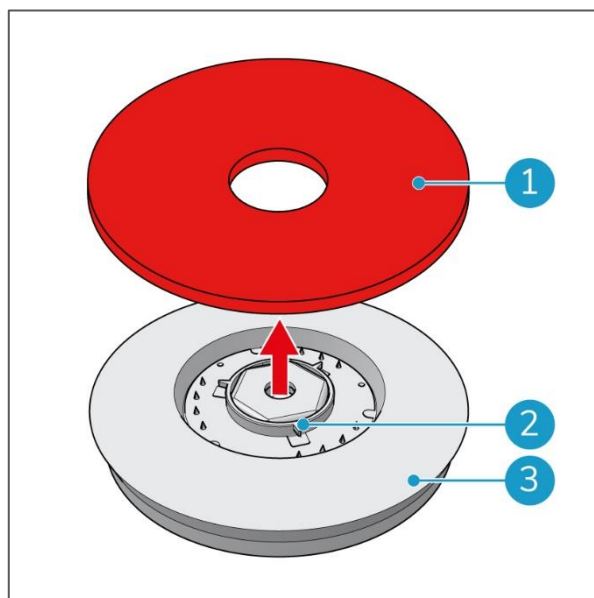

Figure 52



## 7.5 Cleaning the recovery tank

### WARNING



- **DO NOT** pour water in the suction inlet (covered by the rubber flap) as this will damage the vacuum motor;
- wear protective gloves;
- the maximum temperature of any fluid in the recovery tank is 50 °Celsius;
- make sure that you follow your local regulations with regard to wastewater.

1. Position the backside of the CO-BOTIC 65™ in a recovery water disposal area.
2. Turn the ignition key to the OFF position and keep the key with you during maintenance.
3. Open the lid of the recovery tank (Figure 53, pos 4).
4. Check the rubber seal (Figure 53, pos 3), if it is polluted, clean it with a damp cloth.

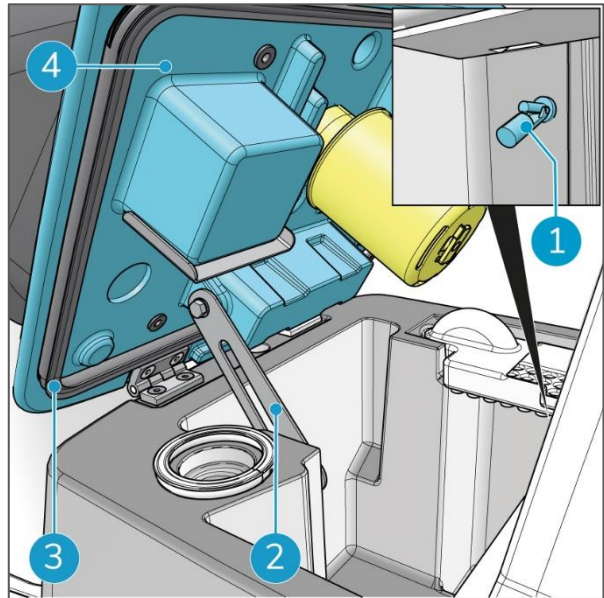

Figure 53

5. Release the recovery tank wastewater tube (Figure 54, pos 2) from the clamp (Figure 54, pos 4).
6. Fold the tube so you create a blockage (Figure 54, pos 3).
7. Place the recovery tank wastewater tube above the recovery water disposal drain.
8. Loosen the lid (Figure 54, pos 1) of the recovery tank wastewater tube.
9. Carefully unfold the tube so the wastewater is released into the drain in a controlled way.

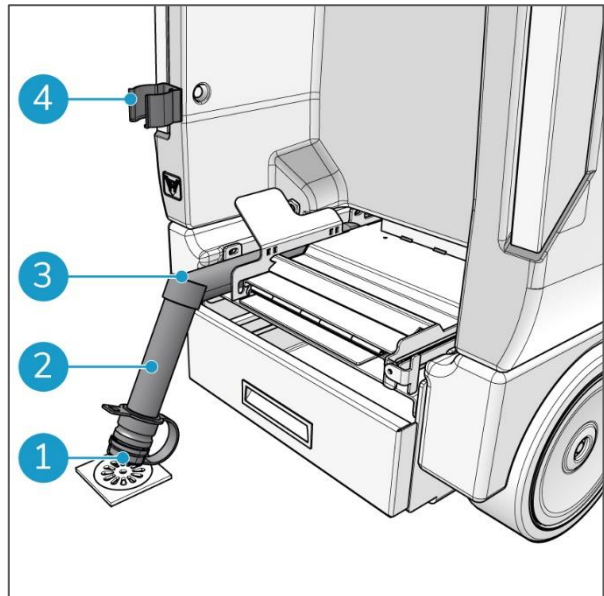

Figure 54





10. When the recovery tank is empty, hose down the tank with water (Figure 53).
11. Clean the underside of the lid with water (Figure 53).
12. Clean the float switch (Figure 53, pos 1) with water to avoid that it sticks.
13. When the recovery tank is clean, place the recovery tank wastewater tube in the clamp (Figure 54, pos 4).
14. Tighten the lid of the recovery tank wastewater tube (Figure 54, pos 1). Make sure it seals correctly to avoid false air being sucked in.



### ATTENTION

For easy use and good sealing, clean and grease the sealant ring in the lid of the recovery tank wastewater tube daily.

#### 7.5.1 Cleaning the separator

1. Turn the yellow cup (Figure 55, pos 2) from the separator (Figure 55, pos 1) anti clockwise to remove it.

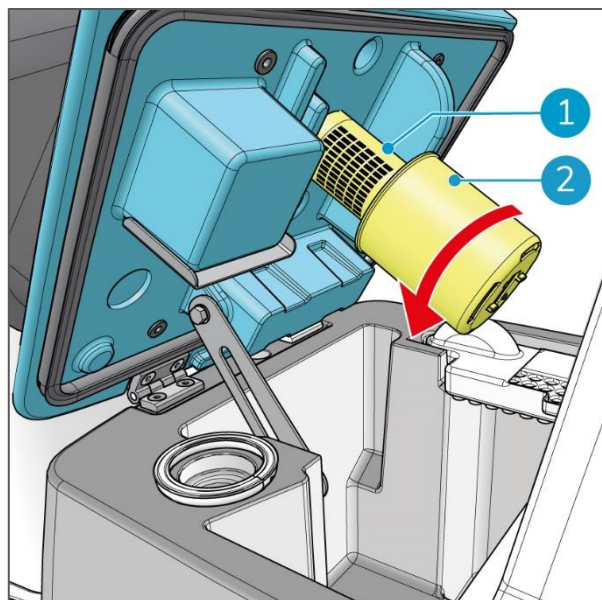

Figure 55

2. Clean the yellow cup with tap water, above a sink (Figure 56, pos 1).
3. Clean the separator with a hose (Figure 56, pos 2).
4. Turn the yellow cup clockwise to tighten it.

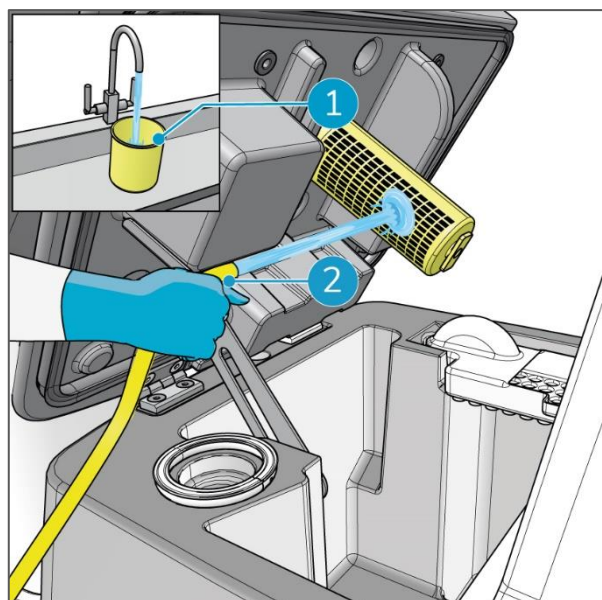

Figure 56



## 7.5.2 Cleaning the recovery water inlet



### CAUTION

Wear protective gloves when cleaning the recovery water inlet as sharp debris may be attached to it.

1. Remove the recovery water inlet (Figure 57, pos 1).

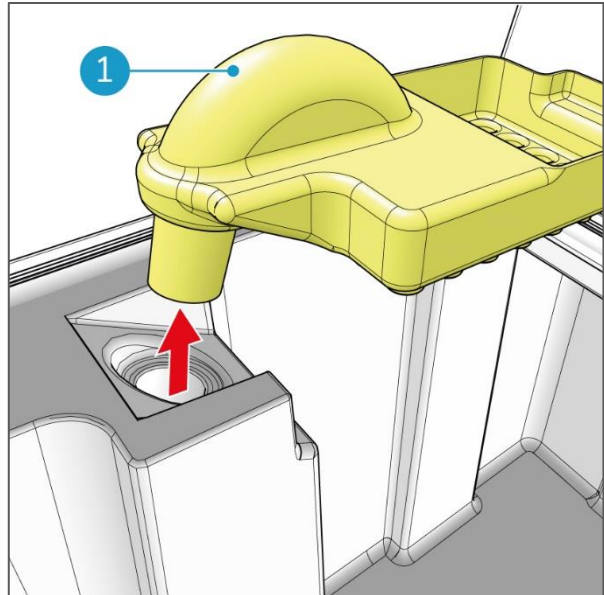

Figure 57

2. Remove the debris by hand and clean it with tap water and a brush (Figure 58, pos 2) above a sink.
3. Rinse it with tap water (Figure 58, pos 1).
4. Replace the recovery water inlet.
5. Unlock the safety hook (Figure 53, pos 2) and close the lid of the recovery tank

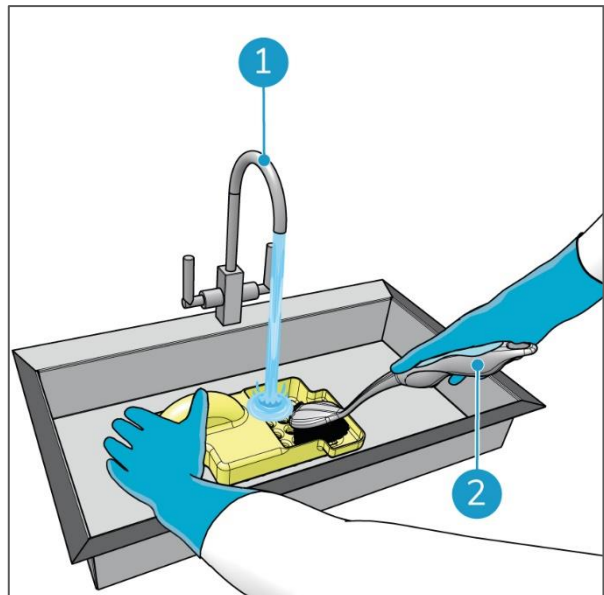

Figure 58

## 7.6 Cleaning the detergent filter and detergent tank



### WARNING

Make sure that you follow your local regulations regarding wastewater.

1. Remove the detergent tank by the handle (Figure 59, pos 2) and put it on a level surface.
2. Open the yellow filler cap (Figure 59, pos 1).

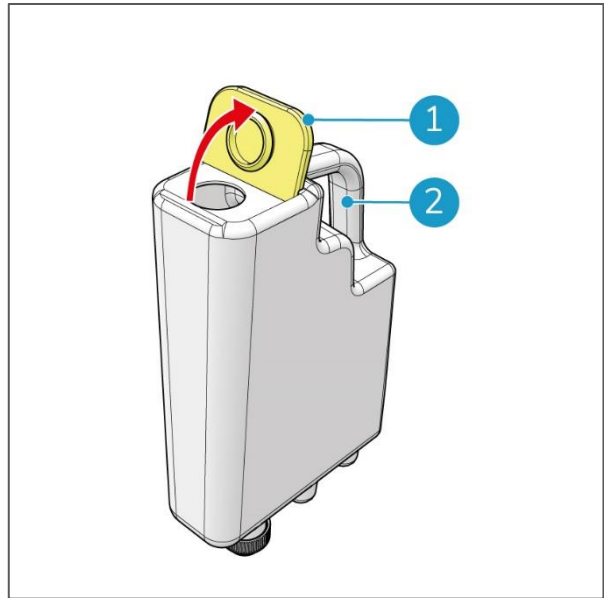

Figure 59

3. Hold the detergent tank by the handle and pour in approx. 2 liters of water, use a funnel. Shake it. Pour the contents into the recovery tank (Figure 60, pos 1).

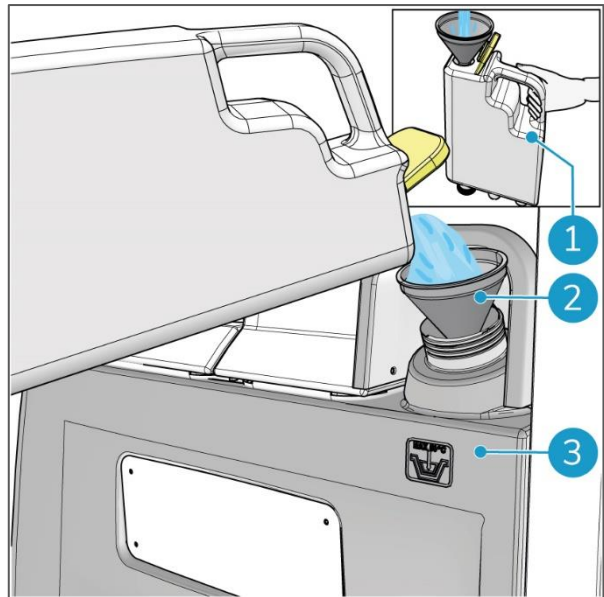

Figure 60



4. Turn the detergent tank upside down.
5. Unscrew the white cap (Figure 61, pos 1), it holds the detergent filter (Figure 61, pos 2) in place.
6. Take of the cap and the filter and rinse both with tap water above a sink (Figure 62, pos 1).
7. Place the filter in the cap (Figure 61).
8. Screw the cap into the bottom of the detergent tank (Figure 61) and make sure it seals tight.

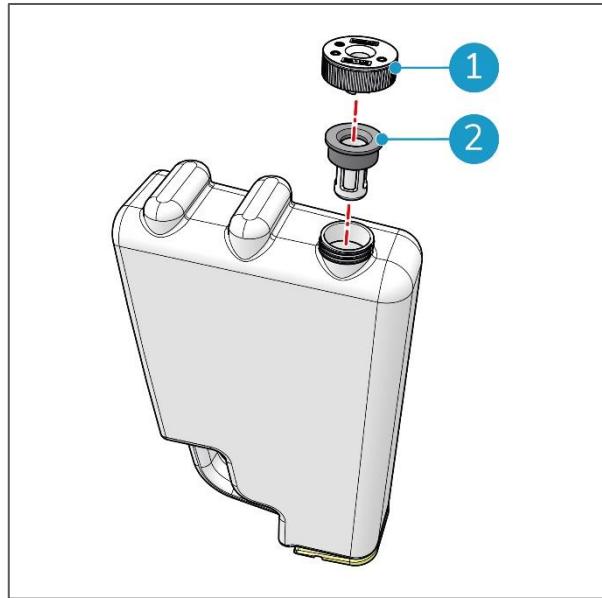

Figure 61

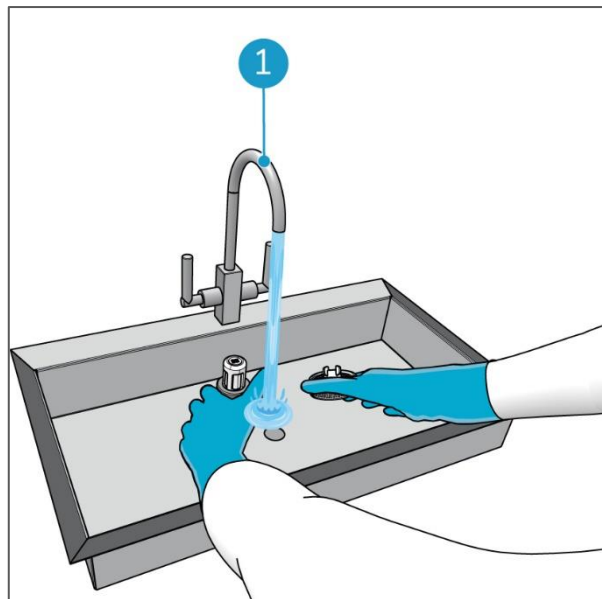

Figure 62



9. Fill the detergent tank with detergent and close the yellow filler cap. Make sure it seals tight.
10. Place the detergent tank back on the CO-BOTIC 65™.
11. Press the tank downward to make sure that the valve (Figure 63, pos 2) is locked onto the detergent tank connector (Figure 63, pos 1).
12. Wash your hands with tap water.

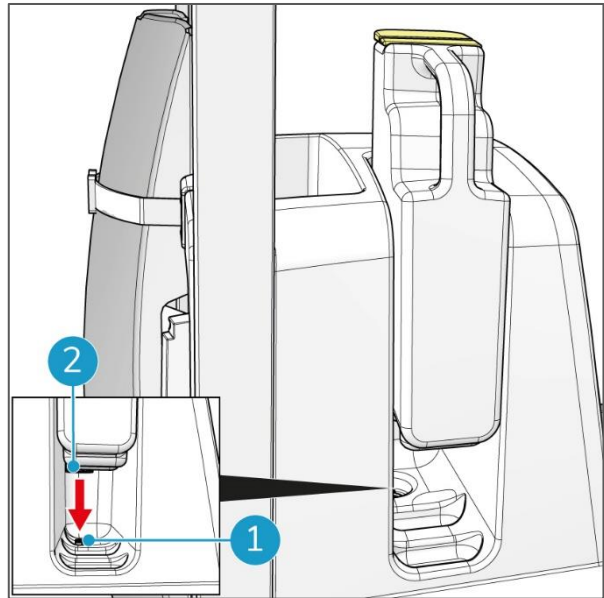

Figure 63

## 7.7 Charging the batteries



### ATTENTION

The batteries with the blue clips are all placed on the left side and the batteries with the grey clips are all placed on the right side.

1. Turn the ignition key to the OFF position and keep the key with you during maintenance (Figure 64, pos 1).

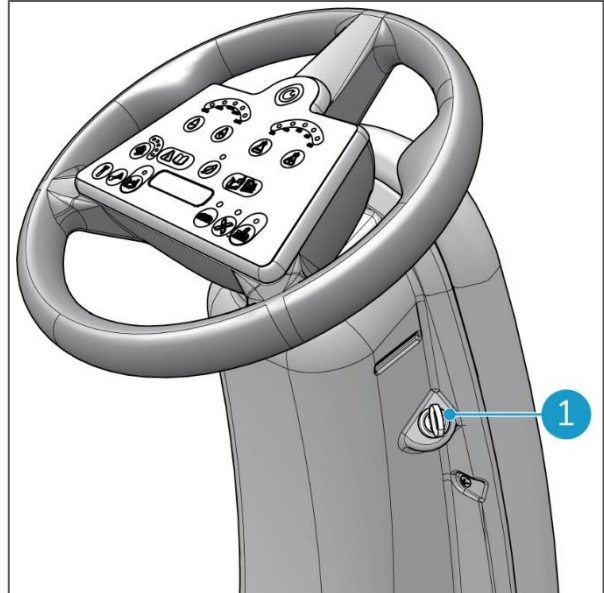

Figure 64

2. Pull out the locking pin on the left side (Figure 65, pos 2) of the battery drawer.
3. Pull out the battery drawer using the black handle (Figure 65, pos 1) until it locks into place.

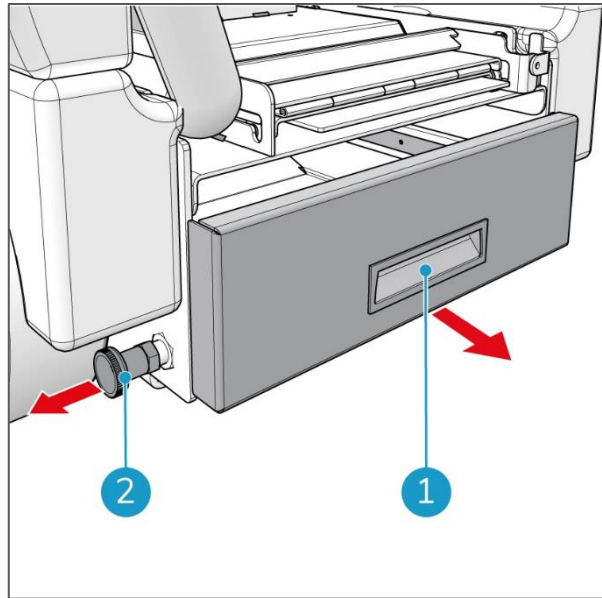

Figure 65

4. Press the clips (Figure 66, pos 1) of each i-power® 14 battery pack slightly towards each other and lift it out.
5. Charge the i-power 14 battery packs in the i-charge® 9 battery charger. Please refer to the user manual of the i-charge 9.
6. Replace back the fully charged batteries. When they "click" they are locked into place.
7. Pull out the locking pin on the left side (Figure 65, pos 2) of the battery drawer.
8. Push the battery drawer into the CO-BOTIC 65™ by the black handle (Figure 65, pos 1) until it locks into place.

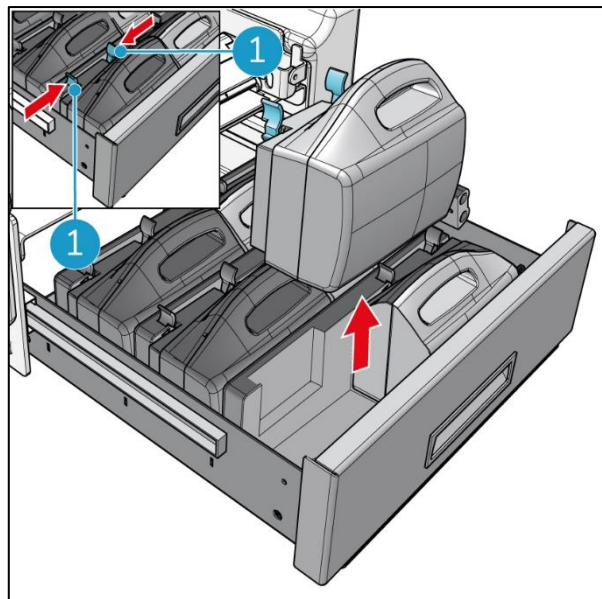

Figure 66

9. Turn the ignition key to the ON position.
10. Wait a few seconds. The display should indicate 100% and all 10 bars of the battery level display should be visible (Figure 67, pos 1). The CO-BOTIC 65™ is ready for a new working cycle.

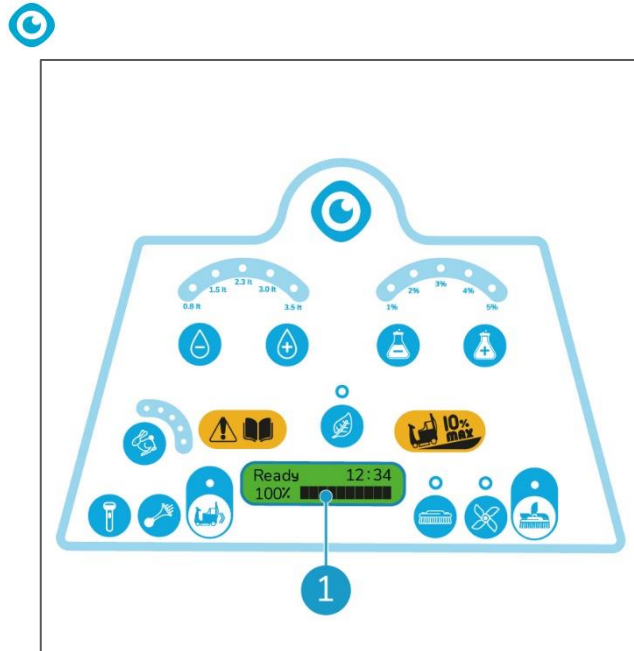

Figure 67

## 7.8 Unloading, loading and refilling the i-mop® lite

### 7.8.1 Unloading and loading

1. Loosen the strap holding the i-mop lite® (Figure 68, pos 1).
2. Unlock the blue lock (Figure 68, pos 2).
3. Pull out the ramp and unfold it (Figure 68, pos 3).
4. Unload the i-mop lite.

To load the i-mop lite, perform steps 1 to 4 in reversed order.

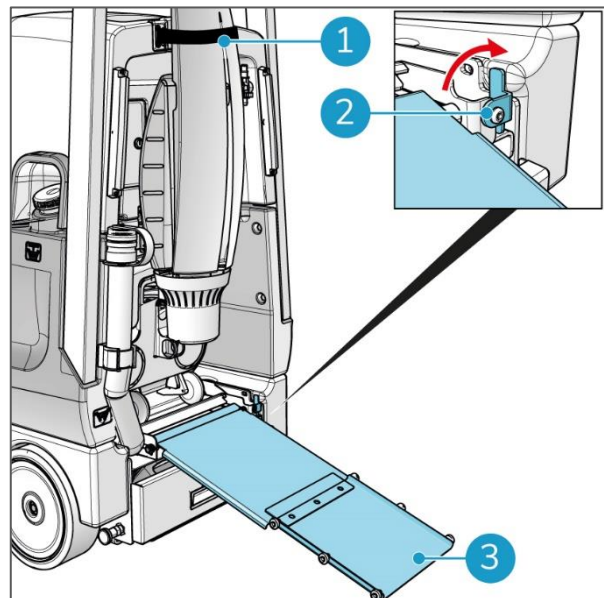

Figure 68

### 7.8.2 Refilling the cleaning solution tank of the i-mop lite



#### **ATTENTION**

Make sure you have the user manual of the i-mop lite by hand.



1. Remove the cleaning solution tank from the i-mop lite®, please refer to the user manual of the i-mop lite.
2. Take the filling tube out of the clamps (Figure 69, pos 1).
3. Open the stopper of the i-mop lite (Figure 69, pos 4).
4. Place the filling tube into the tank (Figure 69, pos 5).
5. Open the red valve (Figure 69, pos 3).
6. Push the yellow button (Figure 69, pos 2). The solution will be pumped into the i-mop lite tank.
7. Push the yellow button again to stop.
8. Perform step 2 to 5 in reversed order.
9. Place the i-mop solution tank back on the i-mop lite. Please refer to the user manual of the i-mop lite.

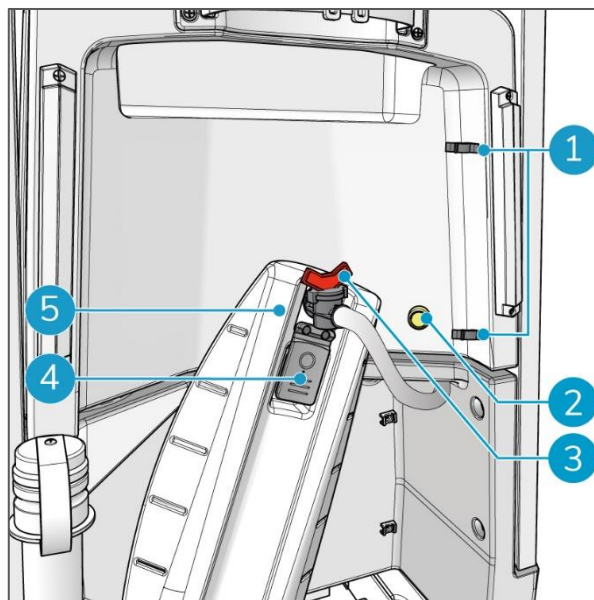

Figure 69

## 7.9 Cleaning the i-mop® lite plateau

First unload the i-mop lite, see section 7.8.1. Wipe the plateau on which the wheels of the i-mop lite rest (Figure 70, pos 1) with a damp cloth.

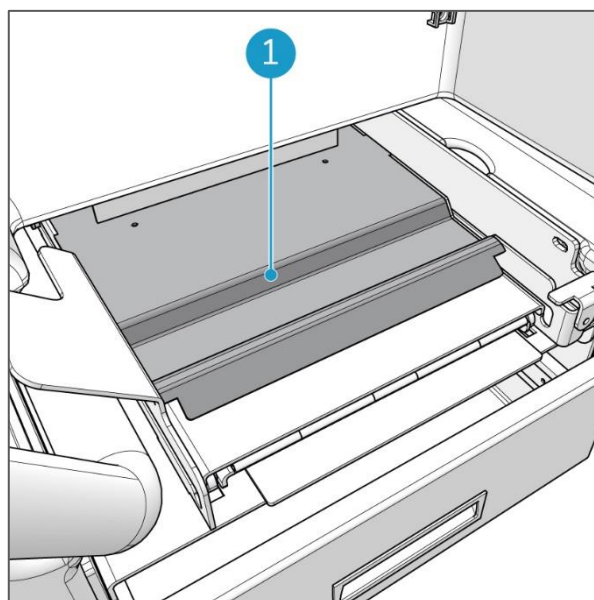

Figure 70



## 7.10 Cleaning the suction line

1. Take place on the seat behind the steering wheel.
2. Turn the ignition key to the ON position. After a few seconds the text "Ready" appears on the display (Figure 71, pos 2).
3. Press the push button (Figure 71, pos 1). The squeegee moves to its lowest position.
4. Turn the ignition key to the OFF position and remove it. Keep the key with you during maintenance.

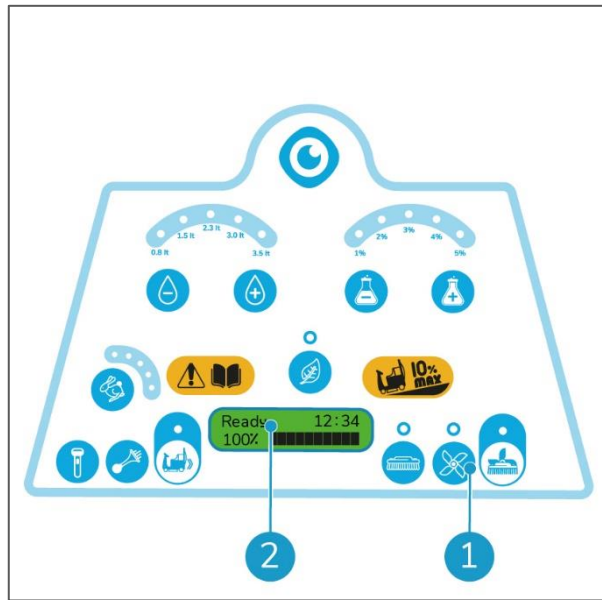

Figure 71

5. Remove the vacuum hose from the hose connector of the squeegee (Figure 72, pos 1).
6. Place the vacuum hose end above a recovery water disposal drain (Figure 72, pos 2).

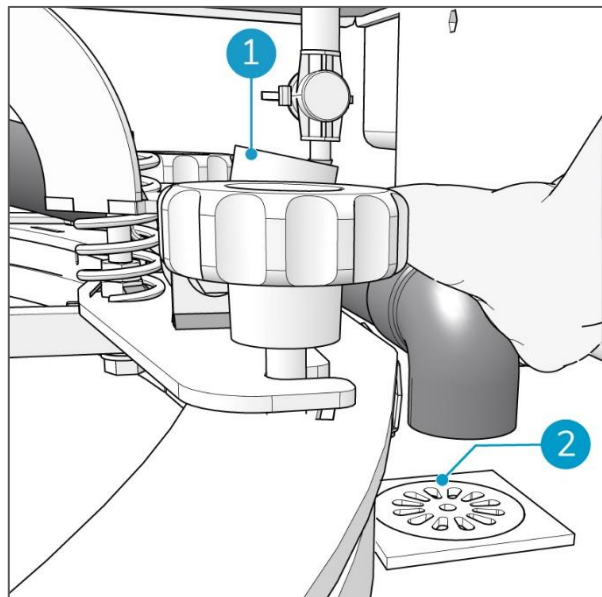

Figure 72



7. Open the lid of the recovery tank.
8. Remove the recovery water inlet (Figure 73, pos 1).
9. Place the water hose in the recovery water inlet and flush the suction line.
10. When the suction line is clean, replace the vacuum hose on the hose connector of the squeegee (Figure 72, pos 1).
11. Replace the recovery water inlet.
12. Close the lid of the recovery tank.
13. Take place on the seat behind the steering wheel.
14. Turn the ignition key to the ON position. After a few seconds the text "Ready" appears on the display (Figure 71, pos 2).

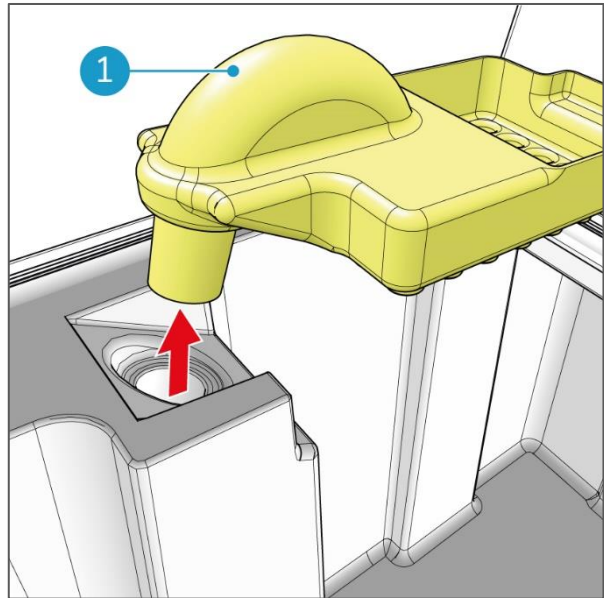

Figure 73

### 7.11 Cleaning the water filter

1. Turn the ignition key to the OFF position and keep the key with you during maintenance.
2. The water filter is positioned under the right front side of the CO-BOTIC 65™ (Figure 74, pos 1).
3. Turn the cover of the water filter (Figure 74, pos 2) anti-clockwise to remove it. The water filter has an integrated valve that avoids water running when the filter is open.
4. Remove the water filter (Figure 74, pos 3) from the cover.

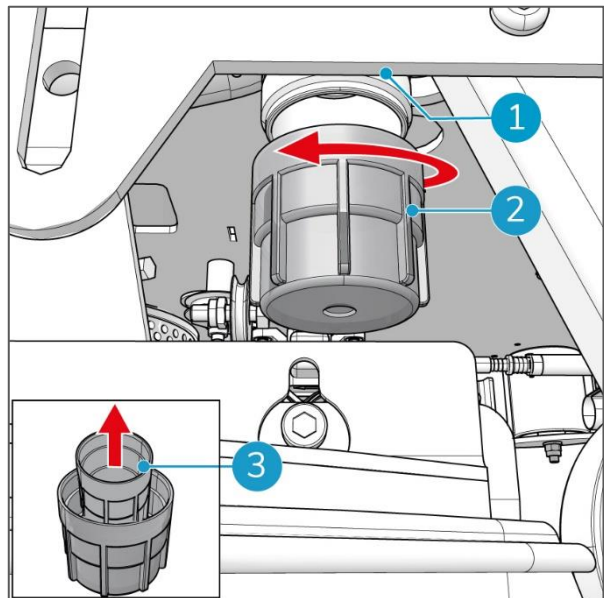

Figure 74



5. Clean the water filter with tap water from the inside outwards. Clean the cover with tap water. Clean both in a sink (Figure 75, pos 1).

6. Replace the water filter in the cover.

Turn the cover clockwise onto its mount.

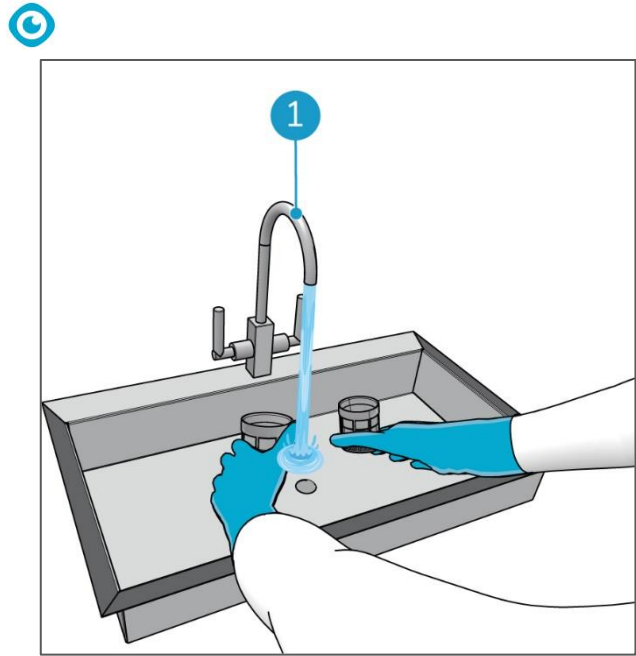

Figure 75

## 7.12 Damaged or worn parts

Damaged or worn parts need to be replaced immediately. Contact your local i-team partner or visit [www.i-teamglobal.com](http://www.i-teamglobal.com) for more information. Always use original spare parts.



## 7.13 Maintenance frequency

Make sure that routine and preventive maintenance are carried out periodically to ensure safe operation. The schedule may vary depending on the type of cleaning work carried out. Failure to carry out maintenance as required may cause damage to the CO-BOTIC 65™ and may cause a risk for the operator. We offer service packs. For more information, please visit [www.i-teamglobal.com](http://www.i-teamglobal.com).

### 7.13.1 Maintenance frequency table

<b>Daily</b>		
Action	Chapter	Frequency
Checking the front and rear squeegee blades	7.3.3	Daily
Cleaning the disc brushes	7.4.3	Daily
Cleaning the recovery tank	7.5	Daily
Cleaning the separator	7.5.1	Daily
<b>Daily or weekly</b>		
Action	Chapter	Frequency
Cleaning the squeegee blades	7.3.3	Daily/weekly *
Cleaning the safety laser scanner	7.1.2	Daily/weekly, depending on the intensity of usage
<b>Monthly</b>		
Action	Chapter	Frequency
Cleaning the detergent filter and detergent tank	7.6	Monthly
<b>Depending on frequency of usage</b>		
Action	Chapter	Frequency
Clean the machine	7.1.1	After each use.
Replacing the front and rear squeegee blades	7.3.3	When worn out or damaged.
Replacing the disc brushes	7.4.4	Depending on the intensity of usage combined with the roughness of the surface.
Replacing the pads	7.4.5	When worn out.
Cleaning the recovery water inlet	7.5.2	After emptying the recovery tank.
Charging the batteries	7.7	When battery levels are low.
Cleaning the i-mop® lite plateau	7.9	When dirty.
Cleaning the suction line	7.10	With poor suction.
Cleaning the water filter	7.11	When the waterflow is blocked.
Checking the machine operating hours	7.2	Depending on the intensity of use. After 250 hours, the following message appears on the display "service required". See 7.13.2.

\* daily: only wipe squeegee, weekly remove blades and clean.



### 7.13.2 Servicing the CO-BOTIC 65™



#### **WARNING**

Service tasks on the CO-BOTIC 65 may only be performed by a trained expert of an authorized i-team workshop by reference to the machine-specific system maintenance.

Service frequency table	
Every 125 hours	See Service Manual.
Every 250 hours	
Every 500 hours	

### 7.14 Storage

- before you store the CO-BOTIC 65, drain and clean the machine;
- before you store the CO-BOTIC 65 open all filler caps to let the tanks air out;
- remove the batteries before storage and charge the batteries for next use;
- store the CO-BOTIC 65 indoors;
- always park the CO-BOTIC 65 on a level, hard surface;
- the storage temperature must be between 0 and +40 degree °C.



## 8 Troubleshooting

Problem	Cause	Solution
<b>No indicator lights up on the panel; the motors do not work.</b>	Battery connector disconnected.	Connect the connector.
	Batteries are flat.	Charge the batteries.
	The emergency stop button is still pressed.	Release it.
	No batteries.	Insert batteries.
<b>The recovery water suction is insufficient.</b>	The squeegee is dirty or the blades are worn out or damaged.	Clean the squeegee or turn/replace the blades.
	The tank lid is not closed properly or the gasket is not working.	Close the lid properly. Clean/replace the gasket.
	Lid of the recovery tank wastewater tube is not sealed.	Close lid properly.
	The suction line is blocked.	Clean the suction line.
<b>There is no recovery water suction.</b>	The recovery water tank is full.	Empty the tank.
	The vacuum hose is disconnected from the squeegee.	Connect the vacuum hose.
	Vacuum motor not working.	Contact service department.
<b>No/insufficient flow of detergent solution (or washing water) to the disc brush.</b>	The detergent solution (or water) filter is dirty.	Clean the filter.
	The detergent solution (or water) tank is dirty.	Clean the tank.
	Detergent tank filter dirty.	Clean detergent tank filter.
	Service valve not closed correctly.	Check the service valve.
<b>The squeegee leaves dirty marks on the floor.</b>	There is debris under the squeegee blades.	Clean the squeegee.
	The squeegee blades are worn out, chipped or torn.	Reverse the blades or replace them.
	The height of the squeegee is not correct.	Contact service department.
<b>The disc brushes or the pads are not cleaning.</b>	The disc brushes are excessively worn out and do not touch the floor.	Check the wear indicator on the disc brushes. Replace the disc brushes.
	The pads are excessively worn out and do not touch the floor.	Check the wear on the pads. Replace the disc brushes or the pads.
Problem	Cause	Solution
<b>The CO-BOTIC 65™ sees objects that are not there.</b>	The safety laser scanner is dirty.	Clean the safety laser scanner.
<b>The CO-BOTIC 65 cannot read the location or start point.</b>	The camera is dirty.	Clean the camera.



## 9 Decommissioning and disposal



### ATTENTION

It is the responsibility of the CO-BOTIC 65™ owner to dispose of the product.

At the end of life, the CO-BOTIC 65 still contains valuable resources and needs to be disposed of according to your local laws and regulations regarding recycling of electrical equipment.

Before disposal, please make sure to:



1. Remove the batteries for separate disposal (see section 7.7).

#### TIP:

**Alternatively, keep the batteries for use in another piece of i-team equipment.**

2. Remove all loose components such as the disc brush, squeegees, plastic parts and hoses.
3. Dispose all items according to your local laws and regulations.

#### TIP:

**Contact your local i-team partner to explore all possibilities of returning components at the end of life of your CO-BOTIC 65.**





## 10.2 Specifications

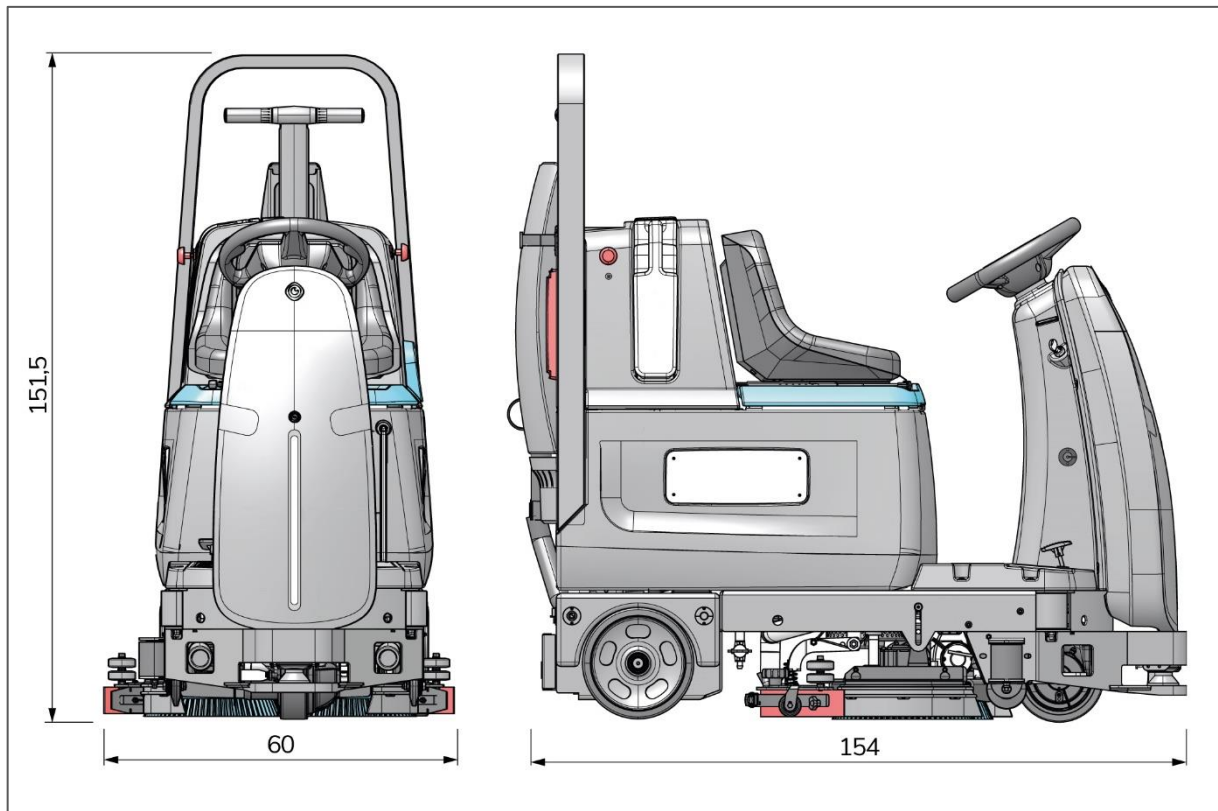

Machine size (L x W x H):	154 x 60 x 151.5 cm
Working width disc brush deck:	61 cm
Working width squeegee:	79 cm
Typical Operational Weight (GVV) (CO-BOTIC 65™ with 6 Li-Io batteries + i- mop lite + chemical tank):	208 kg
Gross Vehicle Weight (GVW automatic) (CO-BOTIC 65):	274 kg
Gross Vehicle Weight (GVW manual) (CO-BOTIC 65 incl. 75 kg for operator):	349 kg
Li-on batteries:	DC (25.2V, 14 Ah, 2117 Wh in total)
Battery capacity:	6 batteries *14 Ah = 84 Ah
Operation time of batteries:	120 min
Operating temperature:	5° C up to +40° C
Storage temperature:	-20° C up to +70° C
Humidity:	30% up to 90%
Disc brush pressure:	24.8 gr/cm <sup>2</sup>
Disc brush speed:	175 RPM
Solution tank capacity:	58 L
Detergent tank capacity:	5.5 L
Recovery tank capacity:	54 L
Vibration:	Acceleration: 0.299 m/s <sup>2</sup>





Noise levels:	Operators ear when seated: $L_{pAT}=64,3$ dB(A) Average around the machine: $L_{pf}=68,5$ dB(A) Sound power (sticker): $L_{wA}=84,4$ dB(A)
Theoretical performance (automatic):	2196 m <sup>2</sup> per hour
Theoretical performance (manual):	2745 m <sup>2</sup> per hour
Practical performance (automatic):	1118 m <sup>2</sup> per hour
Practical performance (manual):	1400 m <sup>2</sup> per hour
Speed:	Forward (automatic): max. 3.6 km/h Forward (manual): max. 4.5 km/h Reverse (manual): max. 3 km/h
Turning circle:	Left: 166 cm Right: 215 cm
Maximum slope normal operation:	2%
Maximal truck ramp (without bumper and safety laser scanner):	18%
Working lights:	YES
Autobrake:	YES
i-mop lite storage:	YES
Disc brush wear indicator:	YES
Operation-hour counter:	YES



## The i-Story

It's not just about cleaning machines.

It's about the well-being of people and the planet.

We are stoked about cleaning, thrilled about sustainability and wholeheartedly dedicated to keep on innovating.

We believe effective cleaning is more than just the removal of soil. It means ensuring the health and safety of people, while making the job easier, simpler, more efficient and even fun. It means consistent results all over the world, while protecting the world. And it means creating partnerships to grow our global force for better cleaning. After all, it takes a team.

**The i-team.**

### Made Blue

By operating i-mops, your partners, clients and users lower the water footprint whilst contributing positively to the availability of water in the world. Every day an i-mop is turned on, Made Blue simultaneously ensures someone else on the planet gets access to clean water. For every liter that the i-mop uses in operations, the i-team and Made Blue mirror clean drinking water in a developing country. The planet is a beautiful place with over 7 billion people. Humans need water to live, breathe, and enjoy their lives. Worldwide 2,7 billion people suffer from a shortage of drinking water. For 780 million people this situation is permanent each year 3,5 million people die because of this. That's why Made Blue invests in projects in developing countries. We are a proud partner of Made blue. Made Blue mirrors the water used by i-team to create clean water in developing countries. 1 liter for 1 liter.



**MADE BLUE**



Access to clean water for All.



## **i-team Professional b.v.**

Hopenkuil 27b, 5626 DD Eindhoven, The Netherlands

Telephone: +31402662400

Email: [hello@i-teamglobal.com](mailto:hello@i-teamglobal.com)

Internet: [www.i-teamglobal.com](http://www.i-teamglobal.com)